

# ELECTRIC CHAIN HOIST

## Operating manual

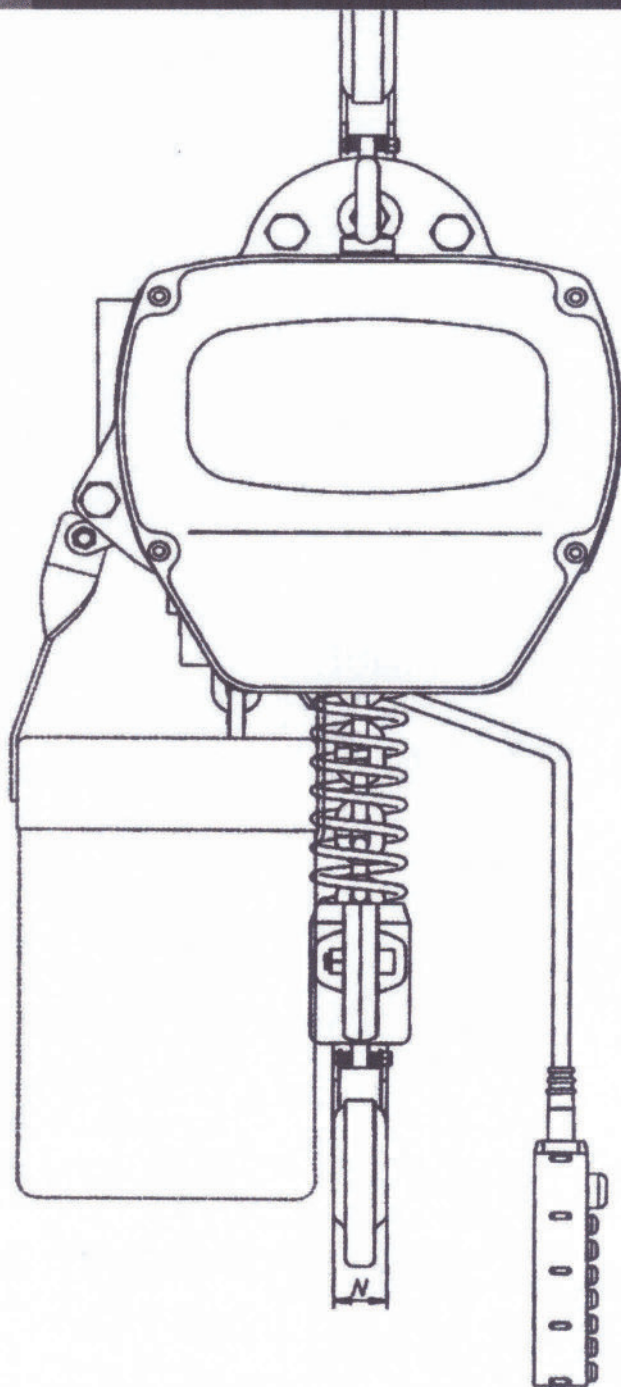

# Content

## Safety First

1	Preface	1
2	Main specifications	2
2.1	Table of specifications	2
2.2	Machine degree and service life	3
2.3	Safety devices	5
2.4	Technical parameters of electric chain hoist	5
2.5	Electric trolley	7
3	Safety rules	8
4	Installation	10
4.1	Unpack of Electric Chain Hoist	10
4.2	Voltage	10
4.3	Installation of Electric Chain Hoist	10
4.4	Installation of electric chain hoist with electric trolley	13
5	Operation	15
6	Maintenance and overhaul	16
6.1	Maintenance	16
6.2	Overhaul	16
7	Wiring diagram	20
8	Drawing and parts list	33
9	Common problems and processing	49
10	Instructions of using and inspecting for electric chain hoist	50

# Safety First

Any hoisting equipment may have potential risks to cause personal injuries or property damage.

If operators do not follow the proper operation instructions and pay no attention to precaution, the occurrence of risks will greatly increase. Thus, it is required that every operator should read through and be familiar with the operation manual and precautions before operation to ensure the safe operation.



If any part of the manual has the alarming signs as indicated at the right and left and the part is underlined, it indicates that the part is vital safety description or precaution. And operators must fully followed, otherwise, it may endanger the operators or others or property.

Hence, before operate electric chain hoist, please read through the manual and precautions.

## 1. Preface

The manual can assist you in correct installing operating and maintaining your electric chain hoist,ensure your hoist to operate safely with the highest efficiency.

Before you use the hoist,please read through the manual to know about the correct procedure and operation,as well as preventative maintenance to guarantee you to have faithful and reliable service.

In order to provide the parts you need to replace in the shortest time,please provide us with the following data when you contact us:

- (1) Type of the hoist you purchased
- (2) Product serial number of the hoist you purchased
- (3) Name of the parts needed (it had better to attach part description).

We believe you will find the electric chain hoist will work for you satisfactorily for years.If you have any questions,please do not hesitate to contact us.

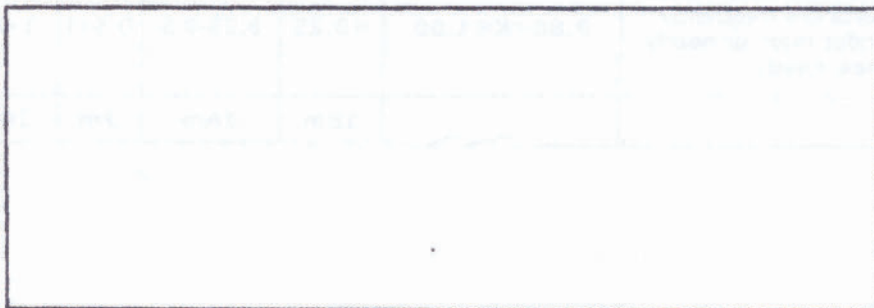

(Please ask the distributor to affix its seal)

## 2.2 Machine degree and service life

The service and safety of the electric chain hoist can be guaranteed only under the condition that it is operated according to the following.

The design of the hoist conforms to 1Am of FEM (Table 2.21)

The description is detailed in table 2.2

The average operation hours per day and total operation hours are calculated on the basis of load distribution.

**Table 2.2 Categories of machine degrees**

Load types	Definition	Cubic meters Value represented	Average operation hours per day(hours)					
			≤2	2-4	4-8	8-16	≤16	>16
1(light)	The mechanism and parts are frequently under light load, and there is no max. load other than exceptional conditions.	$K \leq 0.50$	≤2	2-4	4-8	8-16	≤16	>16
2(middle)	The mechanism and parts are frequently under light load, but also under max. load with low frequency.	$0.50 < K \leq 0.63$	≤1	1-2	2-4	4-8	8-16	≤16
3(heavy)	The mechanism and parts are frequently under middle and heavy load.	$0.63 < K \leq 0.80$	≤0.5	0.5-1	1-2	2-4	4-8	8-16
4 (Super-heavy)	The mechanism and parts are frequently under max. or nearly max. Load.	$0.80 < K \leq 1.00$	≤0.25	0.25-0.5	0.5-1	1-2	2-4	4-8
			1Bm	1Am	2m	3m	4m	5m

## 2. Main specifications

### 2.1 Table of specifications

The specifications in the following table are applicable to all electric chain hoists.

**Table 2.1 Specifications**

Item		Specification	
Range of working humidity(%)		85 or below85	
Range of working temperature(℃)		-20-+40	
Protection class	Hoist	Ip54	
	Push button	Ip54	
Power supply		3 phase,200-600V,50/60Hz	
Noise degree(dB)	Single speed hoist	81	
	Double speed hoist	81	
Chain specifications	Limit working load	Nominal diameter(mm)	Chain Internal length(mm)
	0.3t,0.5t	6.3	19
	1t,2t,3t	7.1	21
	1.5t,2t,3t	10.0	30
	2.5t,3t,5t,7.5t	11.2	34

#### Remarks

- (1) If your working temperature and humidity are out the range of the value in the table, please ask your distributor for related data.
- (2) Expected operation ways:The hoist is designed to vertically lift in normal atmosphere and working conditions.
- (3) The standard of noise degree is the value measured at 1 meter from the machine under the normal operation.

# ELECTRIC CHAIN HOIST

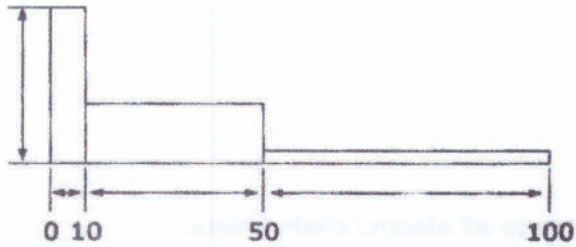

Operation time Load condition 1

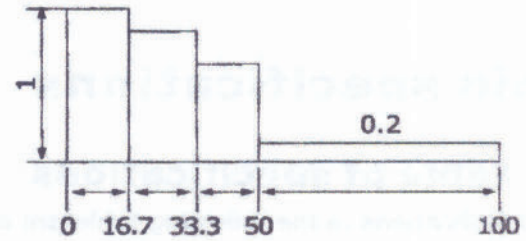

Operation time Load condition 2

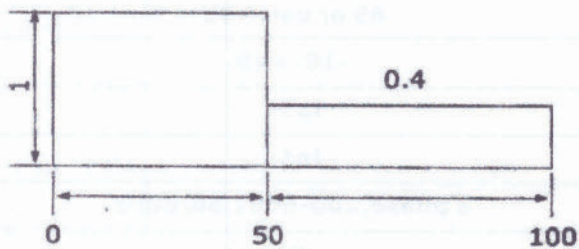

Operation time Load condition 3

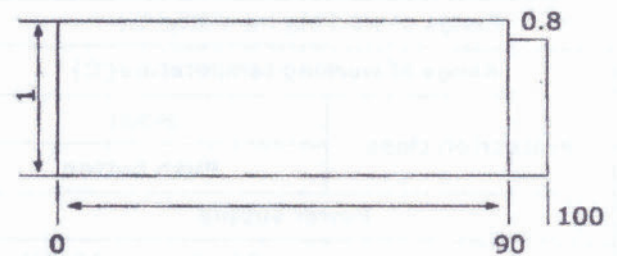

Operation time Load condition 4

**Table 2.21 Standard of lifting motor**

Group		Intermitted operation			Continuous Operation
F.E.M	ISO	Cycles/h	Starts/h	ED(%)	Operation cycle/min
1 DM	M1	15	90	15	7.5
1 CM	M2	20	120	20	7.5
1 BM	M3	25	250	25	15
1 AM	M4	30	180	30	15
2 M	M5	40	240	40	30
3 M	M6	50	300	50	30
4 M	M7	60	360	60	60
5 M	M8	60	360	60	>60

## 2.3 Safety devices

### (1) Side magnetic braking device

It is a unique design which is characterized with the ability that the brake acts immediately as soon as the electric power is cut off.

### (2) Hooks and safety latch

The hook is hot forging with high tensile steel and heat treated to meet the demands on strength and hardness. The operation safety of the lower hook is ensured by its 360° degrees rotation and safety latch.

### (3) Anti-phase protecting device

It is special design to control the circuit not to work and protect the electric motor from being burned in case of wiring error in the power supply.

### (4) Limit switch

It is installed where the weights is lifted on and off to make the motor stop automatically so as to prohibit the chains from exceeding for safety.

### (5) Emergency stop switch(optional)

The button is used to stop the hoist in emergency. It is red, mushroom-shaped push button, located on the top of the push buttons. When the button is pushed, the power supply to the equipped is cut off and the button is locked automatically. Turn it in clockwise to release the button and restart the hoist.

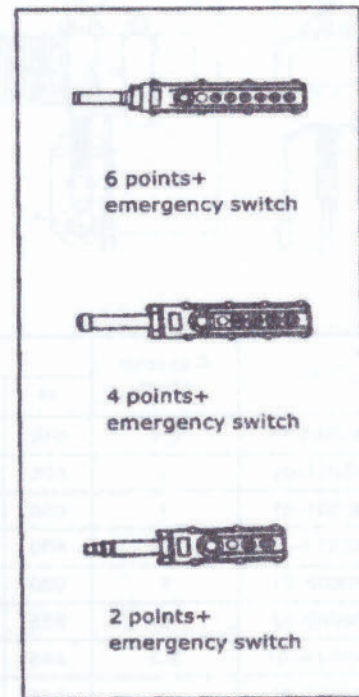

## 2.4 Technical parameters of electric chain hoist

Capacity(ton)	0.3	0.5	1	1	1.5	2	2	2.5	3	3	3	5	7.5
Type	HHBB 0.3-01	HHBB 0.5-01	HHBB 01-02	HHBB 01-01	HHBB 1.5-01	HHBB 02-01	HHBB 02-02	HHBB 2.5-01	HHBB 03-01	HHBB 03-02	HHBB 03-03	HHBB 05-02	HHBB 7.5-03
Remove Lire of Altitude	3/9 m												
Chain Diameter(mm)	6.3	6.3	6.3	7.1	10	10	7.1	11.2	11.2	10	7.1	11.2	11.2
Lifting Speed(m/min)	7.2	7.2	3.6	6.8	8.8	6.6	3.4	5.6	5.6	4.4	2.2	2.8	1.8
Motor Power(kw)	1.1	1.1	1.1	1.5	3.0	3.0	1.5	3.0	3.0	3.0	1.5	3.0	3.0
Power Supply(V)	200-600												
E.D.Rating(%)	40	40	40	40	40	40	40	40	40	40	40	40	40
Chain Fall Number	1	1	2	1	1	1	2	1	1	2	3	2	3

# ELECTRIC CHAIN HOIST

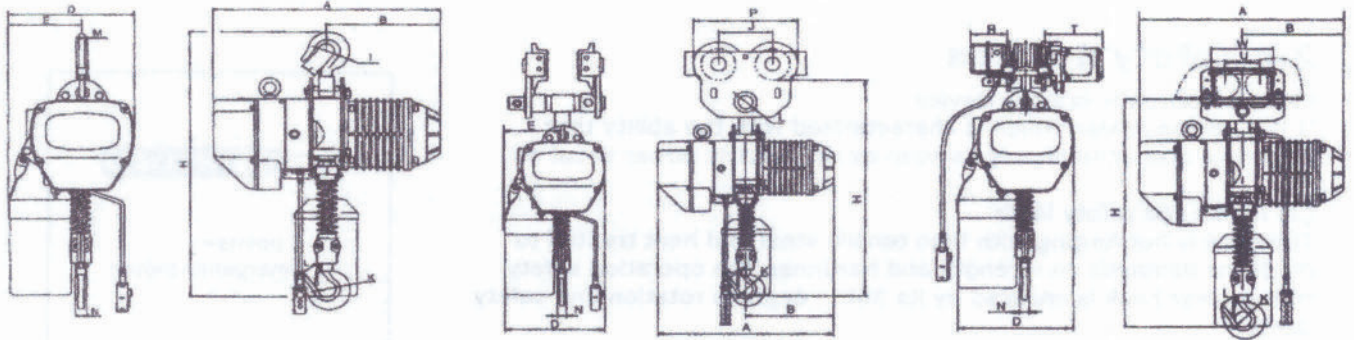

Type	Capacity (Ton)	Unit (mm)											
		H	A	B	D	E	I	J	K	L	M	N	Chain
HHBB0.5-01	0.5	540	455	240	285	165	φ34	28	φ34	25	19	19	φ6.3
HHBB01-02	1	575	455	240	285	165	φ34	28	φ34	25	19	19	φ6.3
HHBB01-01	1	650	520	260	300	176	φ42	32	φ42	32	24	24	φ7.1
HHBB1.5-01	1.5	800	615	295	430	265	φ49	40	φ49	40	30	30	φ10.0
HHBB02-01	2	800	615	295	430	265	φ49	40	φ49	40	30	30	φ10.0
HHBB02-02	2	835	520	260	300	236	φ49	40	φ49	40	30	30	φ7.1
HHBB2.5-01	2.5	845	615	295	430	265	φ59	48	φ59	48	35	35	φ11.2
HHBB03-01	3	845	615	295	430	265	φ59	48	φ59	48	35	35	φ11.2
HHBB03-02	3	950	615	295	430	320	φ59	48	φ59	48	35	35	φ10.0
HHBB03-03	3	950	520	260	350	205	φ59	48	φ59	48	35	35	φ7.1
HHBB05-02	5	1030	615	295	430	325	φ60	48	φ60	48	43	43	φ11.2

Type	Capacity (Ton)	Unit (mm)											
		H	A	B	D	E	K	L	N	I	J	P	Chain
HHBB0.5-01	0.5	555	455	240	285	165	φ34	28	19	φ27	115	221	φ6.3
HHBB01-02	1	630	455	240	285	165	φ42	32	24	φ27	115	221	φ6.3
HHBB01-01	1	635	520	260	300	176	φ42	32	24	φ27	115	221	φ7.1
HHBB1.5-01	1.5	764	615	295	430	265	φ49	40	30	φ31	138	265	φ10.0
HHBB02-01	2	764	615	295	430	265	φ49	40	30	φ31	138	265	φ10.0
HHBB02-02	2	800	520	260	300	236	φ49	40	30	φ31	138	265	φ7.1
HHBB2.5-01	2.5	854	615	295	430	265	φ59	48	35	φ36	157	277	φ11.2
HHBB03-01	3	854	615	295	430	265	φ59	48	35	φ36	157	277	φ11.2
HHBB03-02	3	960	615	295	430	320	φ59	48	35	φ36	157	277	φ10.0
HHBB03-03	3	968	520	260	350	205	φ59	48	35	φ36	157	277	φ7.1
HHBB05-02	5	1007	615	295	430	325	φ60	48	43	φ43	178	332	φ11.2

# ELECTRIC CHAIN HOIST

Type	Capacity (Ton)	Unit (mm)													
		H	A	B	D	E	I	K	L	N	W	U	R	T	Chain
HHBB0.5-01	0.5	610	455	240	285	165	φ 31	φ 34	25	19	206	111	142	231	φ 6.3
HHBB01-02	1	665	455		285	165	φ 31	φ 42	32	24	206	111	142	231	φ 6.3
HHBB01-01	1	650	520	260	300	176	φ 31	φ 42	32	24	206	111	142	231	φ 7.1
HHBB1.5-01	1.5	770	615	295	430	265	φ 36	φ 49	40	30	237	127	142	231	φ 10.0
HHBB02-01	2	770	615	295	430	265	φ 36	φ 49	40	30	237	127	142	231	φ 10.0
HHBB02-02	2	815	520	260	300	236	φ 36	φ 49	40	30	237	127	142	231	φ 7.1
HHBB2.5-01	2.5	830	615	295	430	265	φ 43	φ 59	48	35	265	140	142	231	φ 11.2
HHBB03-01	3	830	615	295	430	265	φ 43	φ 59	48	35	265	140	142	231	φ 11.2
HHBB03-02	3	930	615	295	430	320	φ 43	φ 59	48	35	265	140	142	231	φ 10.0
HHBB03-03	3	940	520	260	350	205	φ 43	φ 59	48	35	265	140	142	231	φ 7.1
HHBB05-02	5	1015	615	295	430	325	φ 54	φ 60	48	43	296	156	142	231	φ 11.2

## 2.5 Electric trolley

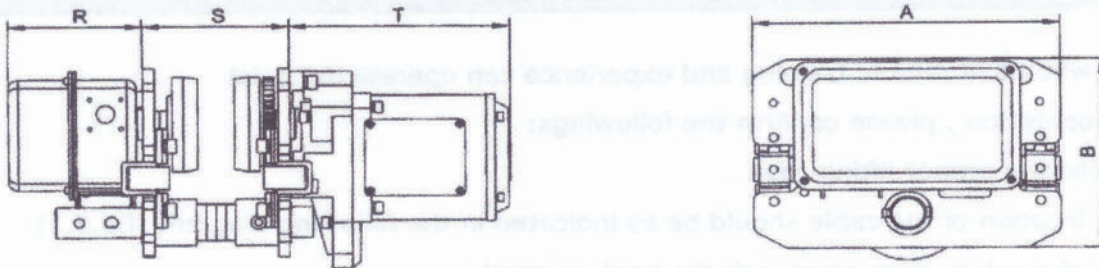

**Table 2.5 Specifications of Electric Trolley(mm)**

Type	Capacity (ton)	A	B	R	T	Speed (m/min) 50Hz	Motor (Kw)	Minimum radius of turn
PX-0.5	0.5	315	212	142	231	12	0.4	0.8
PX-01	1	315	212	142	231	11 or 21	0.4	0.8
PX-02	2	325	220	142	231	11 or 21	0.4	0.8
PX-03	3	340	250	142	231	11 or 21	0.75	1.0
PX-05	5	400	291	142	231	11 or 21	0.75	1.8
PX-7.5	7.5	400	291	142	230	11 or 21	0.75	1.8

## 3.Safety rules



**Danger**

*The hoist is not designed for supporting, loading persons. Any modification, includes upgrade and lifting speed change or any hoist design change must be done by original manufactory or qualified professional engineer.*



**Danger**

*It is forbidden to operate the hoist under the explosive environment.*

- (1) Person who have related training and experience can operate the hoist
- (2) Before operation , please confirm the followings:
  - (a) To use the proper lifting rope .
  - (b) The location of the cable should be as indicated in the following diagram (fig.3.1) and the safety latch must lock the hook correctly .
  - (c) To make sure the weights safe and firm ,then lift it
- (3) The button must be operated stably and firmly .
- (4) Try my best to avoid excessive inching operation .
- (5) Be sure that the motor has been completely stopped before operating in the reverse direction.
- (6) When finished operation , to keep the control cable and the lower hook vertically and statically.
- (7) When lifting ,the weights must be kept balance .Never lift the weight which are not in balance .
- (8) It is forbidden to drag the weights horizontally.(see Fig 3.2)
- (9) It is forbidden to lift the weights by using the chain to bind the weights .(see Fig 3.3)
- (10) When in operation, the operators must face and pay attention to the weights .Be sure not to turn back to or overlook it .

## ELECTRIC CHAIN HOIST

- (11) It is risky to lift the weights over the rated load capacity. And it should not be tried .
- (12) Do not lift goods when the chain is twined .
- (13) Regular inspection to ensure chain is in a good condition, if the chain is damaged, don't operate hoist to lift the weights.

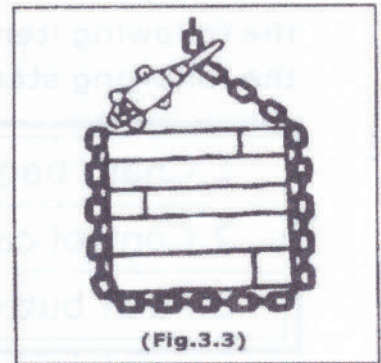
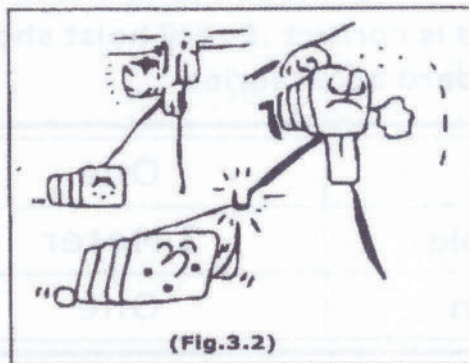
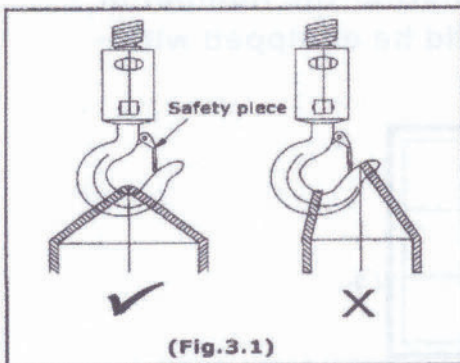

**Warning**

*Never use the chain as a welding electrode*



**Warning**

*Never stand under  
when lifting  
(see Fig. 3.4)*

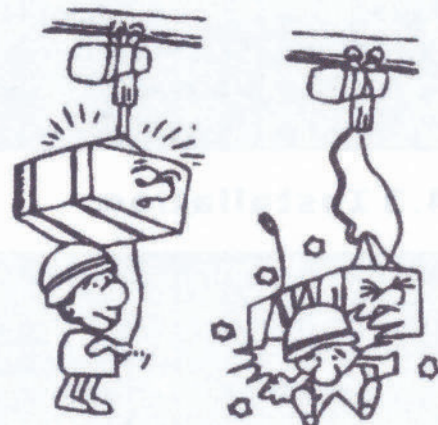

## 4. Installation

### 4.1 Unpacking

After unpacking ,please check carefully to ensure the cable ,gearbox , and motor shell are not damaged ,and check whether the number of the following items is correct .Every hoist should be equipped with the following standard accessories .

1.Chain bag	One
2.Control cable	3 Meter
3.Push button	One

### 4.2 Voltage



#### **Note**

If the voltage of power supply is over or less 10% than standard voltage to operate hoist under the abnormal voltage will result in motor damage , hence , before operation , be sure to confirm whether the voltage of power supply is within the standard range.

### 4.3 Installation



#### **Warning**

It is forbidden to link the power supply before the completion of installation .

## ELECTRIC CHAIN HOIST

4.3.1 Before installing the hoist, please confirm the whole upper hook assembly has been firmly assembled to the hoist body (ensure the chain connection pin is installed properly).

Remarks :If the hoist is equipped with electric trolley, the first step (to separate the upper hook from the hoist body) can be omitted, it is only required to install the hoist between two side plates of trolley, and lock the upper hook.

4.3.2 Assemble chain bag (Fig.4.1)

4.3.3 Link the power supply and operate the push button, the procedure should be performed by professional trained person .(Fig.4.2)

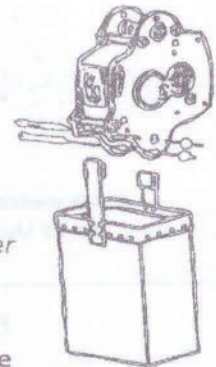

(Fig.4.1)

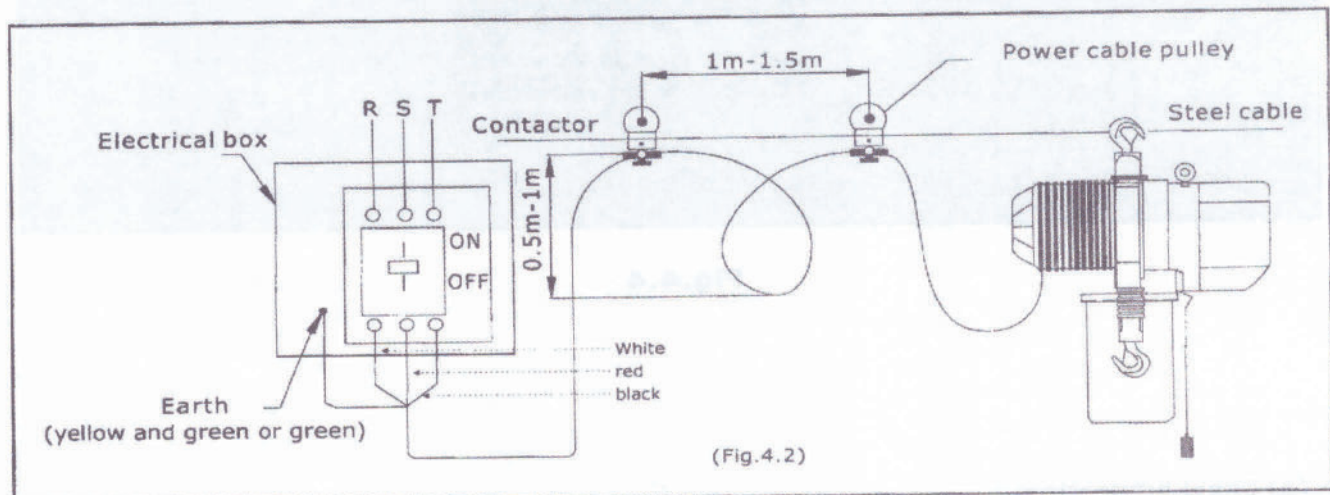

(Fig.4.2)

4.3.4 Operation test

- Press the Ⓚ push button to lower the hoist until the limit spring touches the limit switch, and the motor will stop automatically .
- Press the Ⓛ button until the chain are totally in chain bag and the motor stops .
- Test the function of the emergency stop switch (if the emergency stop switch is selectively purchased )Press button Ⓚ or Ⓛ , and press the emergency stop switch at the same time to check whether the hook can stop immediately .When the emergency switch is pressed ,there will be no response when any other button is pressed .Finally ,turn the emergency switch in clockwise and it will bounce back to the original position .When it bounces back, the hoist can be operated again ,if any of the above -mentioned tests is abnormal , it is required to check the distribution circuit and the self-locking of the emergency switch .
- Check the direction of chain .All welding points should be of the same direction .(Fig 4.3). The operation can not be utterly proper unless all the welding points of chain are in the same line .

## ELECTRIC CHAIN HOIST

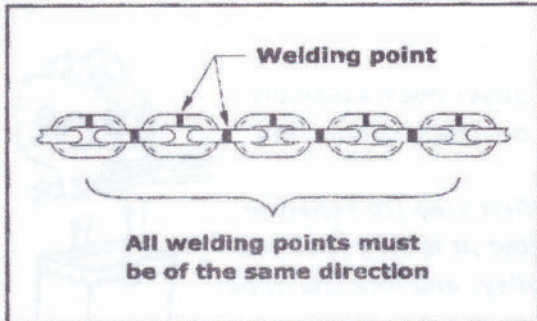

Fig.4.3



Fig.4.4



### Note

If the chain fall is double or even number, it is forbidden to hang the lower hook in the reverse direction to avoid dangers (Fig. 4.4).

Fig.4.4

### (e) Chain lubrication

The degree of chain lubrication plays an important role on chain's service life. It needs to apply machine oil or gear oil regularly to prolong the chain's service life.

The process of lubrication:

1. Keep chain vertically without load .
  2. Erase dust and water stains on chain .
  3. Lubricate each link of chain connection and load pulley.
- After the lubrication, lift the chain up and down without load in order to daub lubrication equably. (Fig.4.5)

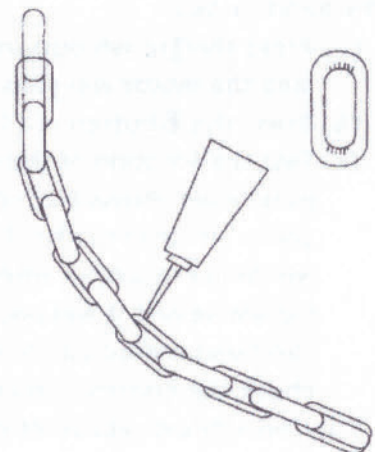
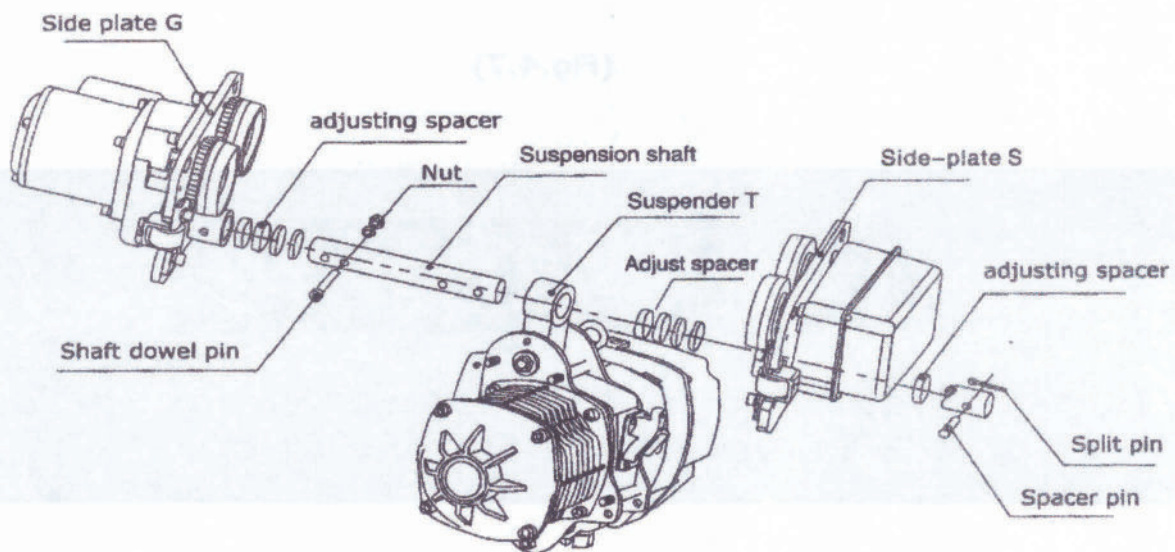

Fig.4.5

## 4.4 Installation of electric chain hoist with electric trolley (See Fig. 4.6)

### (a) Installation of trolley

- (1) Insert the suspension shaft into the side plate G, and fix with them together with bolt and nut.
- (2) Input the suspension shaft with inner adjusting spacer inside, after putting the spacers, the total width should be about half of the width of traversing beam.
- (3) As the Fig. 4.6 shown, do installation step by step. Firstly, install suspender T into hoist body, and insert the shaft into suspender T.
- (4) Secondly, install the adjusting spacers on it. Put side plate S between trolley wheel and electric case. And fix with adjusting spacer.
- (5) The last step: using dowel pin and split pin to fix.



( Fig.4.6)

### (b) Adjust trolley width (Fig. 4.7)

- (1) A refers to the measure value when two side plates stretch outwards totally.
- (2) B refers to the measure value when two side plates clamp inwards totally.
- (3) To adjust the number of thickness of inner spacers, makes B equal to the size when wheels on the two side plates close to beam.
- (4) To adjust the number and thickness of outer spacers, make  $A \leq B + 4\text{mm}$ .
- (5) The disassembling procedures refers to trolley installation, and fixed with dowel pin.

## ELECTRIC CHAIN HOIST

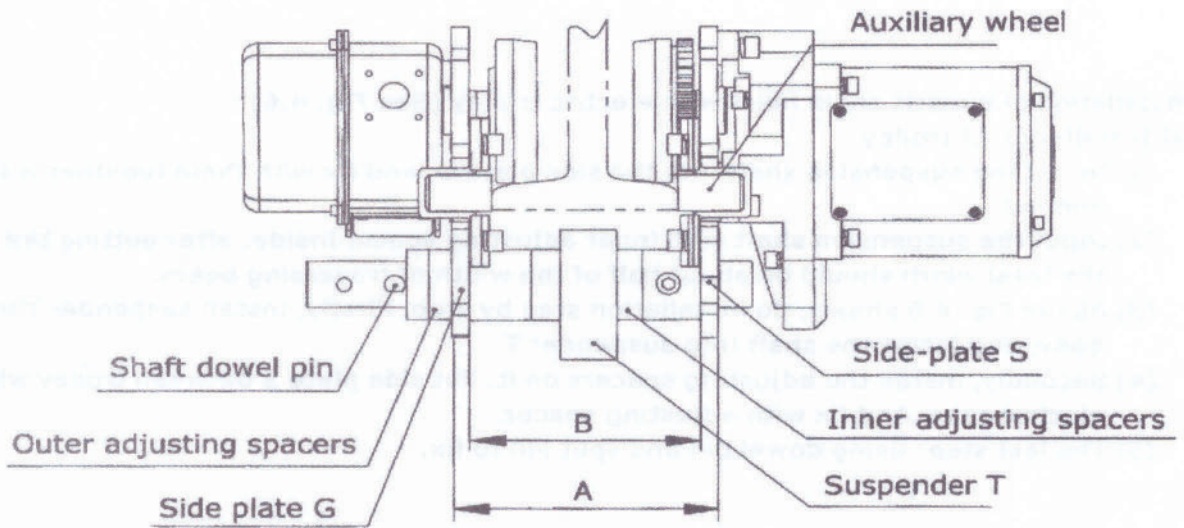

(Fig.4.7)



## **Warning**

*It is forbidden to link the power supply before the completion of installation.*

Warning: please always fix with nuts

(c) Install the trolley on the traversing rail.

1. Under an exceptional circumstance, the most convenient installation way is to make the hoist trolley installed in the traveling rail from the end of the rail.
2. If it is not available with the first way, please do installation as the following: (See Fig.12)
  - 1) Remove the bolt from the suspension shaft hole A. Then insert it into the hole B. Fix it with split pin.
  - 2) Outward stretch side plate G and side plate S. Lift the trolley up to the traveling rail to keep both sides of wheel rail and traveling rail at the same level.
  - 3) Firstly support one side plate (G or S), then push the other side plate (S or G) with strength to prevent its shedding from rail. Keep the wheel rail and the traveling rail at the same level.
  - 4) Remove the bolt from the hole B, insert it to the hole A, and fix it with split pin.

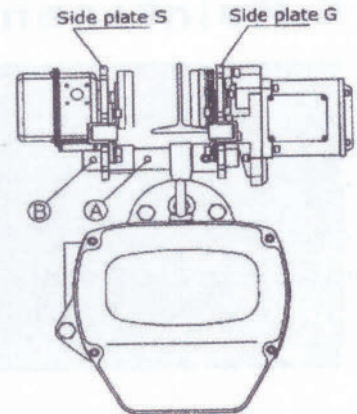

Fig 4.8  
Trolley with the hoist  
mounting to traversing rail

## 5. Operation

After the above-mentioned test and operation testing, the hoist can be normally operated.



### **Warning**

*It is forbidden to link the power supply before the completion of installation.*

- (1) Before operation, the operator must have a clear and unobstructed view of the whole working area.
- (2) Before operation, the operator must check whether the whole working area is safe and free of risks.
- (3) When the trolley is operated, the operator must be careful to prevent from the situation that the reverse force caused by swing of the weights, may be over the load of trolley while changing the trolley operation direction.

## 6. Maintenance and overhaul



**Danger**

Except monthly examination about performance of brake and limit switch, never have it maintained under loading condition.



**Danger**

Before maintenance, be sure to label "danger" and "overhaul" on the power supply and controller.

### 6.1 Maintenance

(1) When the gear operation times reaches more than 500 hours, to check the amount of lubrication, and later check the lubrication every 3 months regularly.

*Remarks: we recommend that using the engine oil same as grade ISOVG46 oil.*

(2) Check the dryness of the hoist parts frequently, and forbid to abuse the hoist; otherwise, its durability may be reduced.

(3) If it is operated outdoors, please add a protection cover.

### 6.2 Overhaul

(1) Daily inspection: before daily operation, please check the following items:

(a) Proper power supply.

(b) Test the "up", "down" and "emergency stop" (if installed) without load.

(c) The motor works normally.

(d) there is no abnormally or excessively high noise.

(e) the safety latch of the lower hook functions properly and is free of faults.

(f) the rotatable or movable parts and the limit switch as well as the brake function normally.

(g) the chain is lubricated well.

(2) Monthly inspection



## Warning

In maintenance, please use the original parts recommended by the manufacturer.

(a) Chain

Any distorted, extended, or worn chain will not be good locked with chain wheel, result in the breakdown or disengaging of the chains. To ensure the safe and normal operation, the internal length and width, external width of the chain must be checked monthly. If in the following situation, the chain must be replaced.

- 1) The internal length of the chain (p) is worn and extended 5% higher than the values as listed in Table 6.1
- 2) The wearing of the diameter of the chain link (d) is lower than the value listed in table 6.1 (The wearing of nominal diameter reaches 10% higher than the original one)

\*\*\*\*\* When the wearing of chain is high, be sure to confirm the wearing of the chain wheel and chain guide \*\*\*\*\*

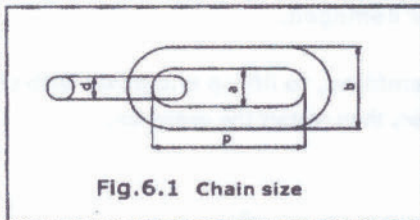

Diameter (mm) (d)	Capacity (ton)	Internal length (mm) (p)	Internal width (mm) (a)	External width (mm) (b)
6.3	0.3, 0.5, 1	19	7.9	22
7.1	1, 2, 3	21	8.9	25
10.0	1.5, 2, 3	30	12.5	35
11.2	2.5-7.5	34	14	39

Table 6.1

(b) Hoist hook

Check the hook carefully. Its crack or distortion is over 5% than original one, it should be replaced. (Please refer to the sizes in the following table)

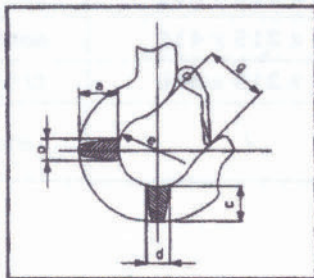

Capacity (ton)	a	b	c	d	e	g
0.5	27	18	25	17	35	28
1	34	24	30	24	42	32
2	46	29	39	30	49	40
3	56	35	49	34	59	48
5	67	43	57	44	60	48
7.5	82	55	80	48	85	80

Table 6.2

# ELECTRIC CHAIN HOIST

## (C) Limit switch



### Warning

It should be inspected by qualified electrician.

Check whether the limit switch operates normally. After clearing, make it covered with a thin layer of lubrication to ensure the normal operation.

## (3) Annual overhaul



### Warning

The annual maintenance should be performed by original manufacturer or distributor.

- (a) To check whether the locking of gear is excessive worn or damaged.
- (b) Replace the oil gearbox thoroughly.
- (c) After the above-mentioned checking and machine reassembling, to lift up and down with the weights several times before normal operation. If it is in good condition, then restart the operation.

### Specification of chain bag

Serial number of chain bag	Chain specifications	Chain length(m)	Size of chain bag(mm)	Material
8#	∅ 6.3	<6	150 x 150 x 350	canvas
8#	∅ 7.1	<8.8	150 x 150 x 350	canvas
12#	∅ 10.0, ∅ 11.2	<10	215 x 215 x 410	canvas
14#	∅ 10.0, ∅ 11.2	10-20	215 x 215 x 500	canvas
Other	∅ 6.3, ∅ 7.1 ∅ 10.0, ∅ 11.2	>20	/	Steel

## Chain gauge--to regularly measure the wearing and elongation

- (1) It is convenient to measure with chain gauge provided by the manufacturer.
- (2) As shown in Fig.6.3 and Fig.6.4, measure the chain internodal distance and diameter with the chain gauge.
- (3) Every link should be measured, and it must be be replaced with a new one if any of the links is found to be abnormal.
- (4) The application of a worn, distorted, or extended chain may result in chain breakdown.
- (5) The replacement of the chain should be entrusted to a service station or a special agent manufacturer. Never replace it by yourself.
- (6) The chain must be replaced in a whole, no partial replacement is allowed.
- (7) If it is the second time to replace chain, the chain transmission core shaft, adjuster, guide wheel should be replaced at the same time.

### Remarks

- (1) The chain should be free of scar and pitting caused by collision.
- (2) There should be no foreign objects ( such as iron, aluminum scrap)

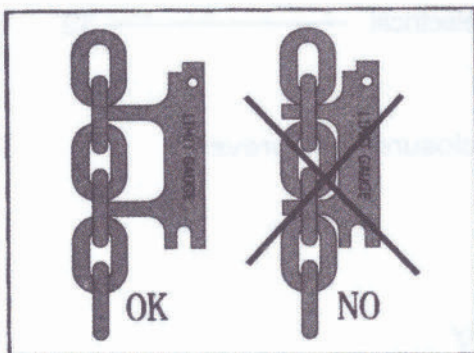

Fig.6.3 Measure of internodal distance

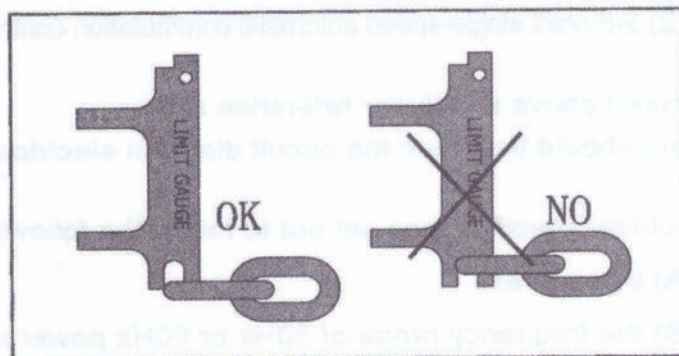

Fig.6.4 Measure of diameter

## 7. Troubleshooting

### 7.1 Wiring Diagram

(1) 2:00 Single Speed	_____	21
(2) 4:00 Single Speed	_____	22
(3) 6:00 Single Speed	_____	23
(4) 2:00 Single Speed	_____	24
(5) 4:00 Single Speed	_____	25
(6) 6:00 Single Speed	_____	26
(7) 2:00 dual speed	_____	27
(8) 4:00 dual speed	_____	28
(9) 4:00 dual speed	_____	29
(10) 2:00 dual speed	_____	30
(11) 4:00 dual speed	_____	30
(12) 2-6-point single-speed automatic commutation control of electrical	_____	32

Pictured above is only for reference line

Users should be inside the circuit diagram electrical enclosure shall prevail.

Electrical specifications set out to follow the following:

- (A) three-phase
- (B) the frequency range of 50Hz or 60Hz power supply
- (C) single-voltage or dual voltage

Voltage Hertz	Dual Voltage	Single Voltage
50Hz	220V/380V 220V/440V	220~600V
60Hz	230V/460V	

## Single Speed 2:00 fixed electrical wiring diagram

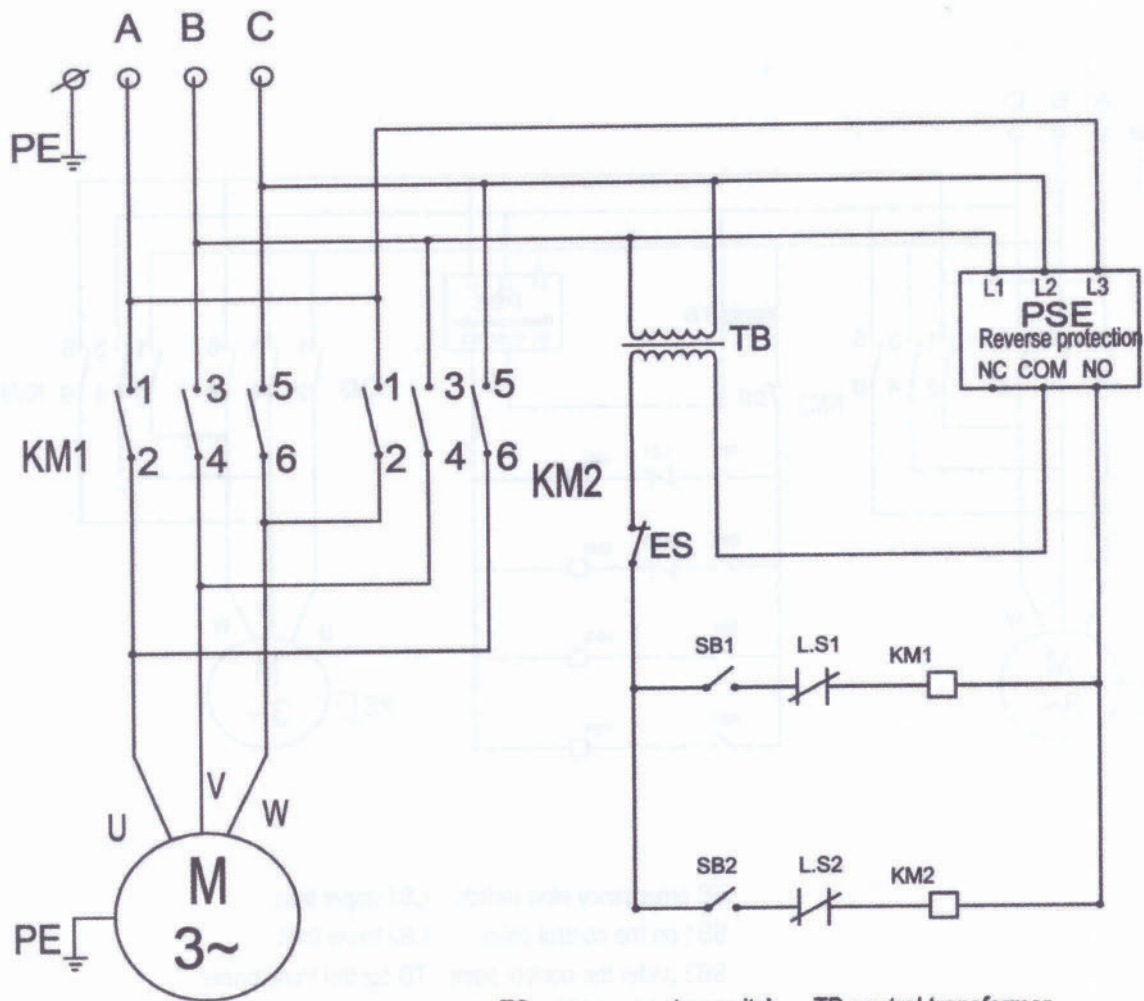

- |                             |                        |
|-----------------------------|------------------------|
| ES emergency stop switch    | TB control transformer |
| SB1 on the control point    | PSE phasing            |
| SB2 under the control point | AC contactor KM1-KM2   |
| LS1 upper limit             | PE Ground              |
| LS2 lower limit             |                        |

## 4:00 run single speed style electrical wiring diagram

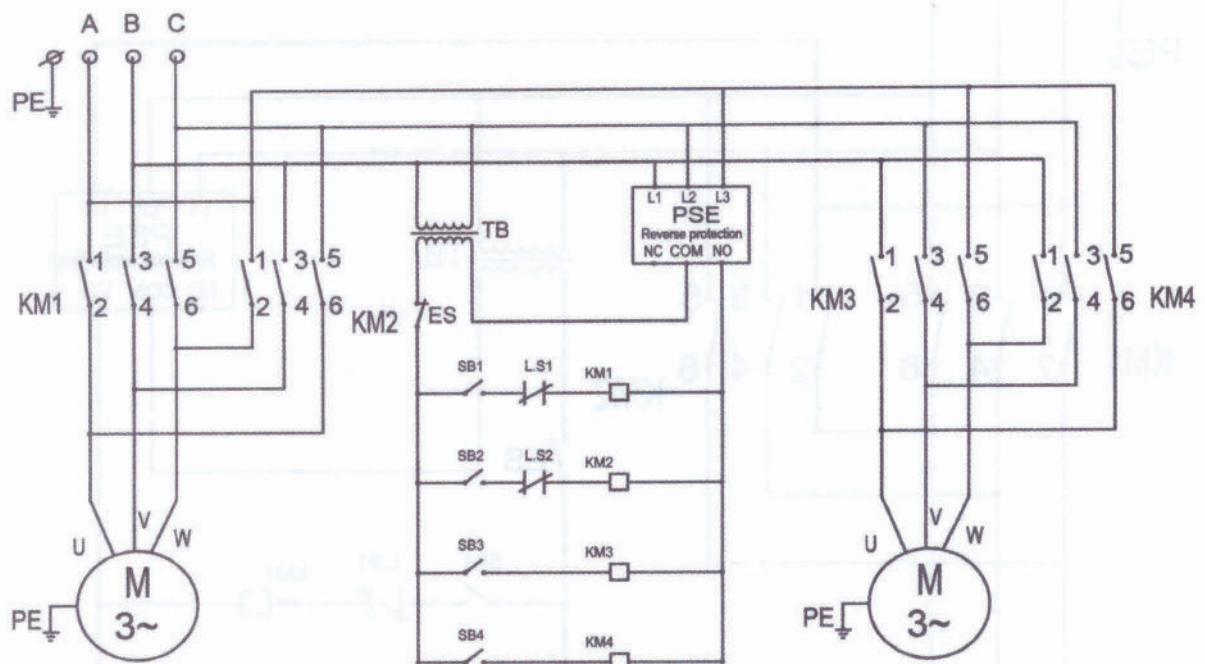

- |                             |                        |
|-----------------------------|------------------------|
| ES emergency stop switch    | LS1 upper limit        |
| SB1 on the control point    | LS2 lower limit        |
| SB2 under the control point | TB control transformer |
| SB3 left control point      | PSE phasing            |
| SB4 right control point     | AC contactor KM1-KM4   |
|                             | PE Ground              |

6:00 run single speed style electrical wiring diagram

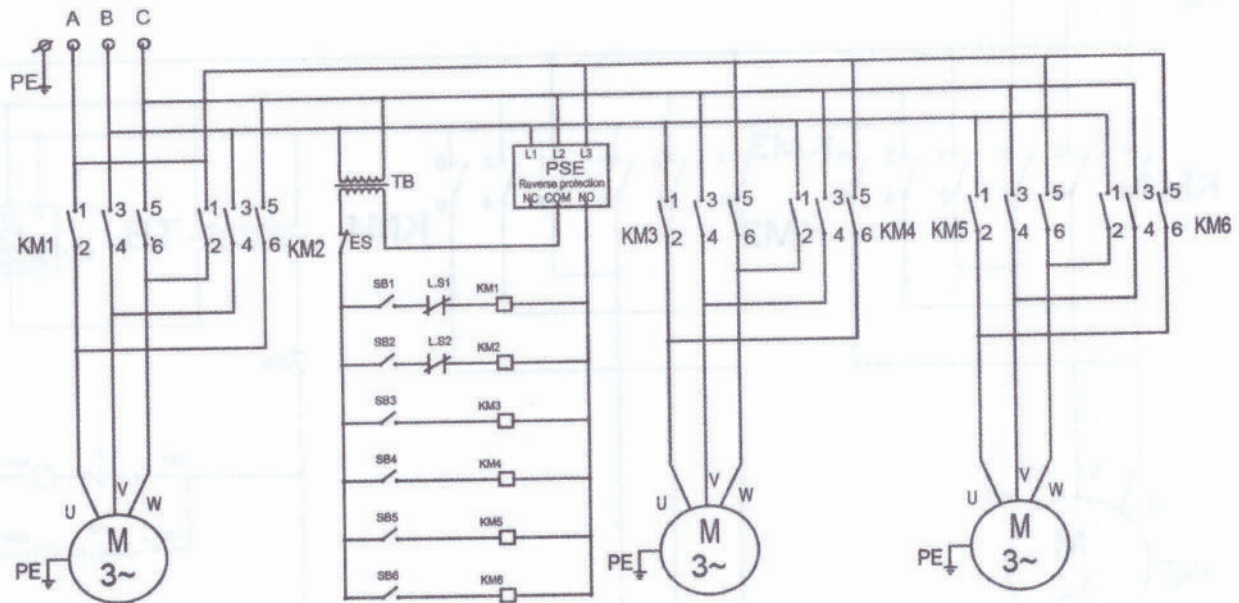

- ES emergency stop switch
- LS1 upper limit
- SB1 on the control point
- LS2 lower limit
- SB2 under the control point
- TB control transformer
- SB3 left control point
- PSE phasing
- SB4 right control point
- AC contactor KM1-KM6
- SB5 front handles
- PE Ground
- SB6 after the control point

## 2:00 two-speed control (4 contacts)

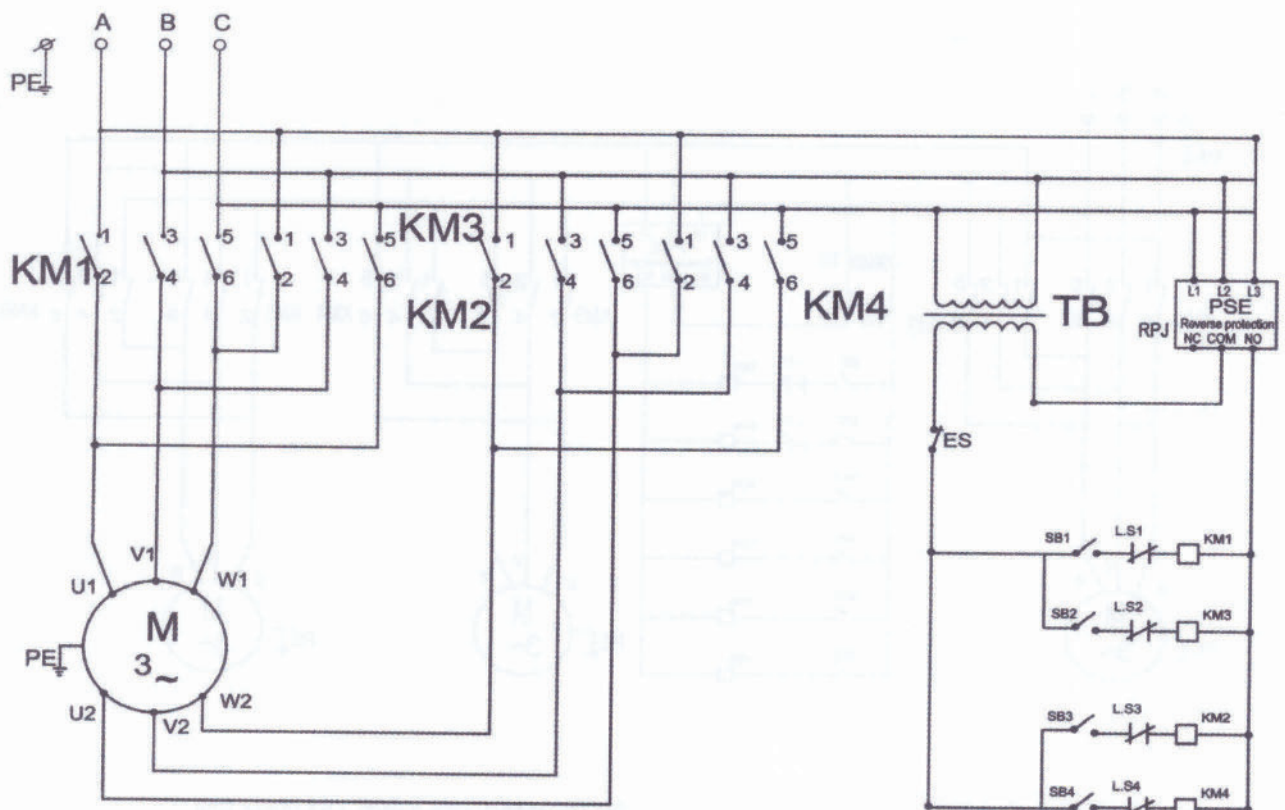

- ES emergency stop switch
- SB1 slower control point
- SB2 faster control point
- SB3 slow down the control point
- SB4 quickly under control points
- LS1 slow upper limit
- LS2 fast upper limit
- LS3 slowly lower limit
- LS4 fast lower limit
- TB control transformer
- PSE phasing
- AC contactor KM1-KM4
- PE Ground

## 4:00 two-speed control (4 contacts)

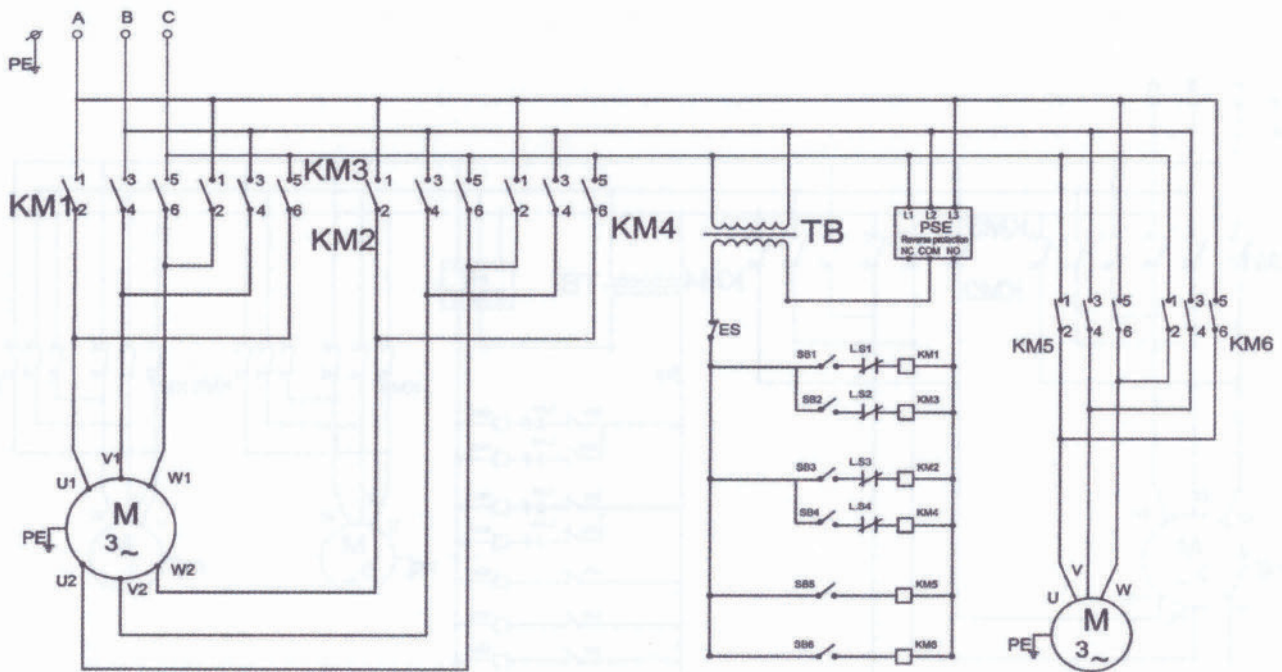

ES emergency stop switch

SB1 slower control point

SB2 faster control point

SB3 slow down the control point

SB4 quickly under control points

SB5 left control point

SB6 right control point

LS1 slow upper limit

LS2 fast upper limit

LS3 slowly lower limit

LS4 fast lower limit

TB control transformer

PSE phasing

AC contactor KM1-KM8

PE Ground

## 6:00 two-speed control (4 contacts)

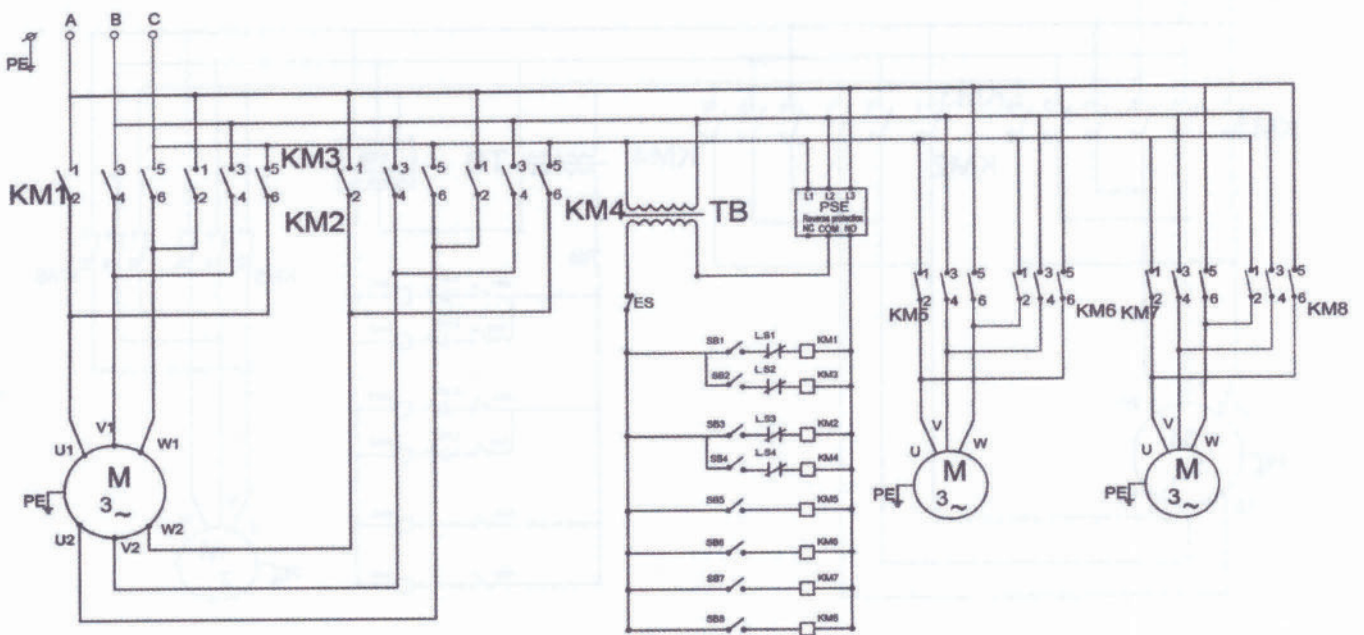

ES emergency stop switch

SB1 slower control point

SB2 faster control point

SB3 slow down the control point

SB4 quickly under control points

SB5 left control point

SB6 right control point

SB7 front handles

SB8 after the control point

LS1 slow upper limit

LS2 fast upper limit

LS3 slowly lower limit

LS4 fast lower limit

TB control transformer

PSE phasing

AC contactor KM1-KM8

PE Ground

## Start with a single-speed 2:00

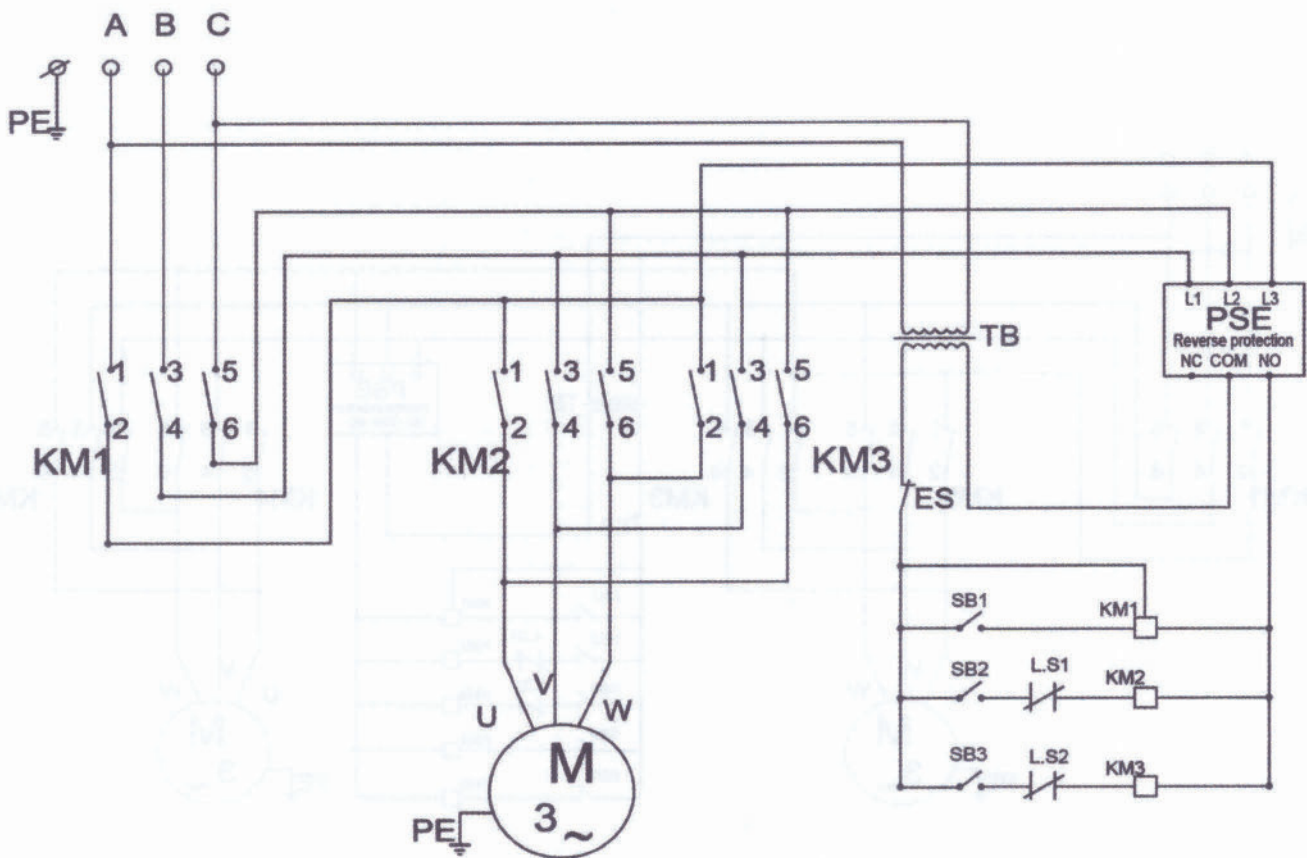

- |                             |                        |
|-----------------------------|------------------------|
| ES emergency stop switch    | LS1 upper limit        |
| SB1 mains contactor         | LS2 upper limit        |
| SB2 on the control point    | TB control transformer |
| SB3 under the control point | PSE phasing            |
|                             | AC contactor KM1-KM3   |
|                             | PE Ground              |

## Single speed 4:00 with start

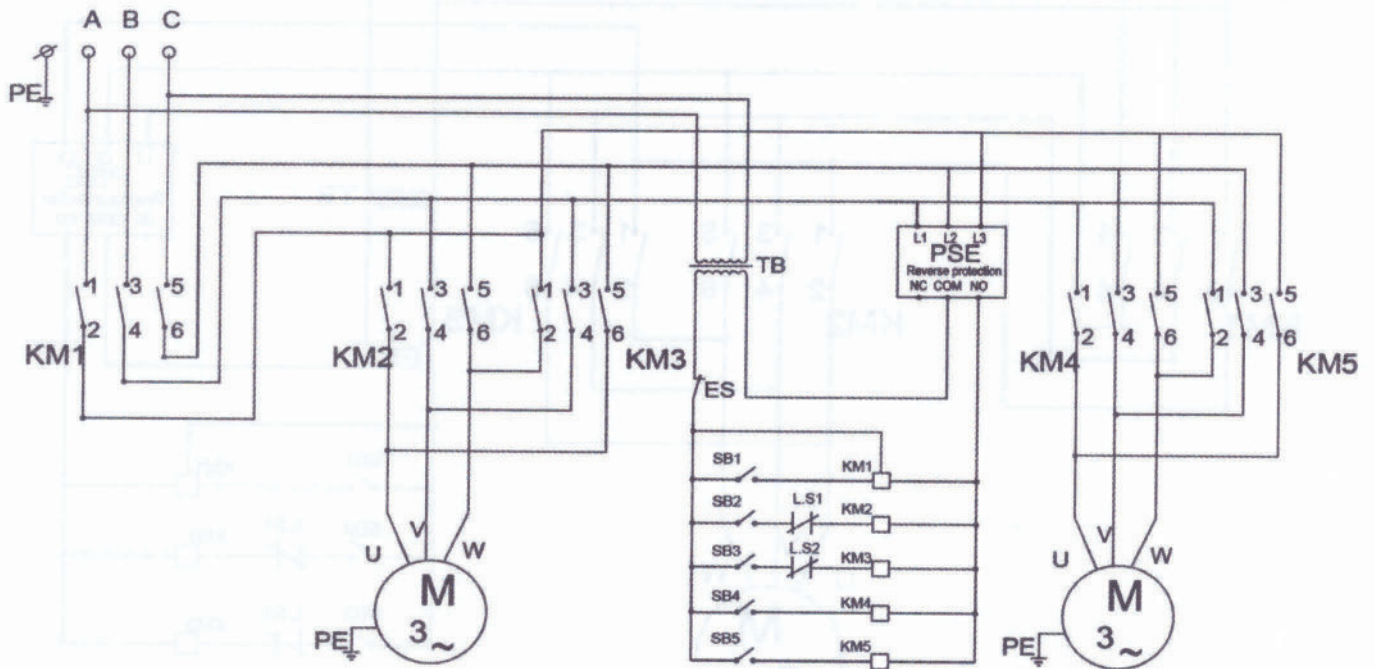

- |                             |                        |
|-----------------------------|------------------------|
| ES emergency stop switch    | LS1 upper limit        |
| SB1 mains contactor         | LS2 lower limit        |
| SB2 on the control point    | TB control transformer |
| SB3 under the control point | PSE phasing            |
| SB4 left control point      | AC contactor KM1-KM5   |
| SB5 right control point     | PE Ground              |

(8A) Single speed 6:00 with start

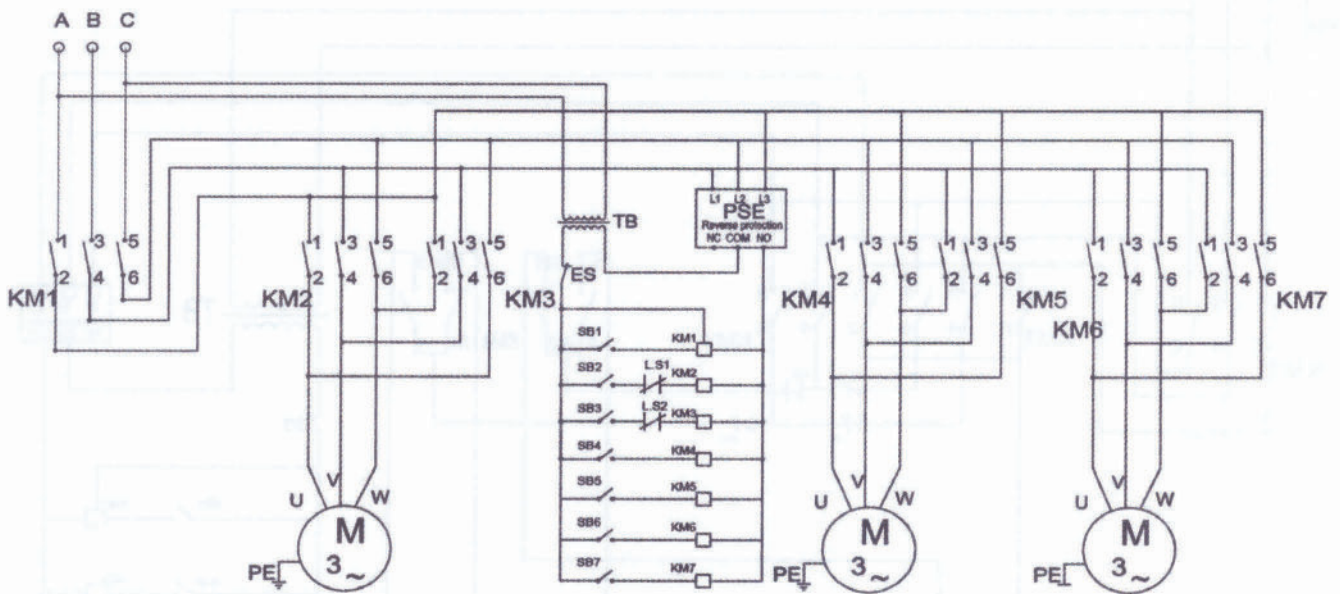

- ES emergency stop switch
- LS1 upper limit
- SB1 mains contactor
- LS2 lower limit
- SB2 on the control point
- TB control transformer
- SB3 under the control point
- PSE phasing
- SB4 left control point
- AC contactor KM1-KM7
- SB5 right control point
- PE Ground
- SB6 front handles
- After the control point SB7

## Start with a two-speed 2:00 (A3)

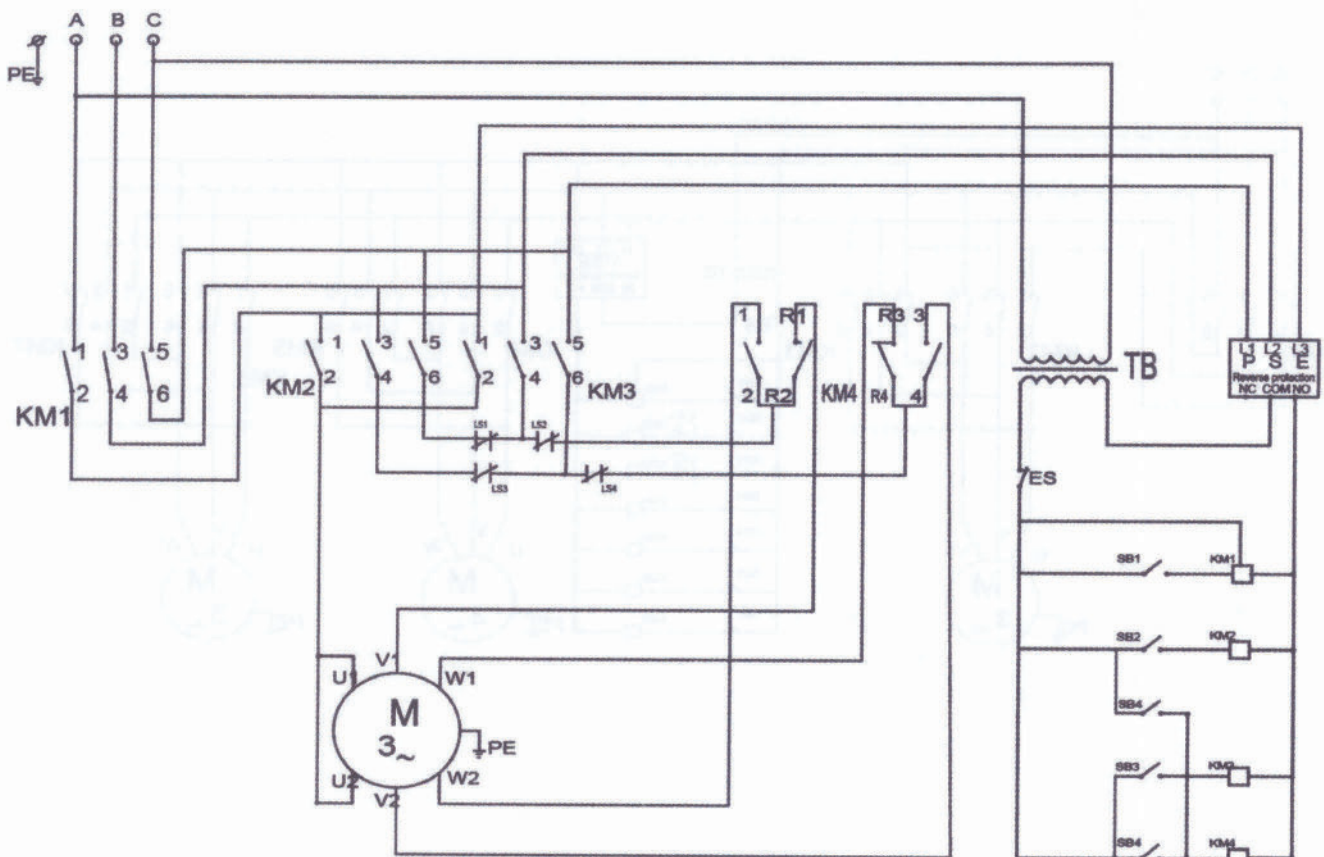

ES emergency stop switch

SB1 mains contactor

SB2 slower control point

SB3 slow down the control point

SB4 rapid control point

LS 1. LS 3 upper limit

LS 2. LS 4 lower limit

TB control transformer

PSE phasing

AC contactor KM1-KM4

PE Ground

Start with a two-speed 4:00 (A3)

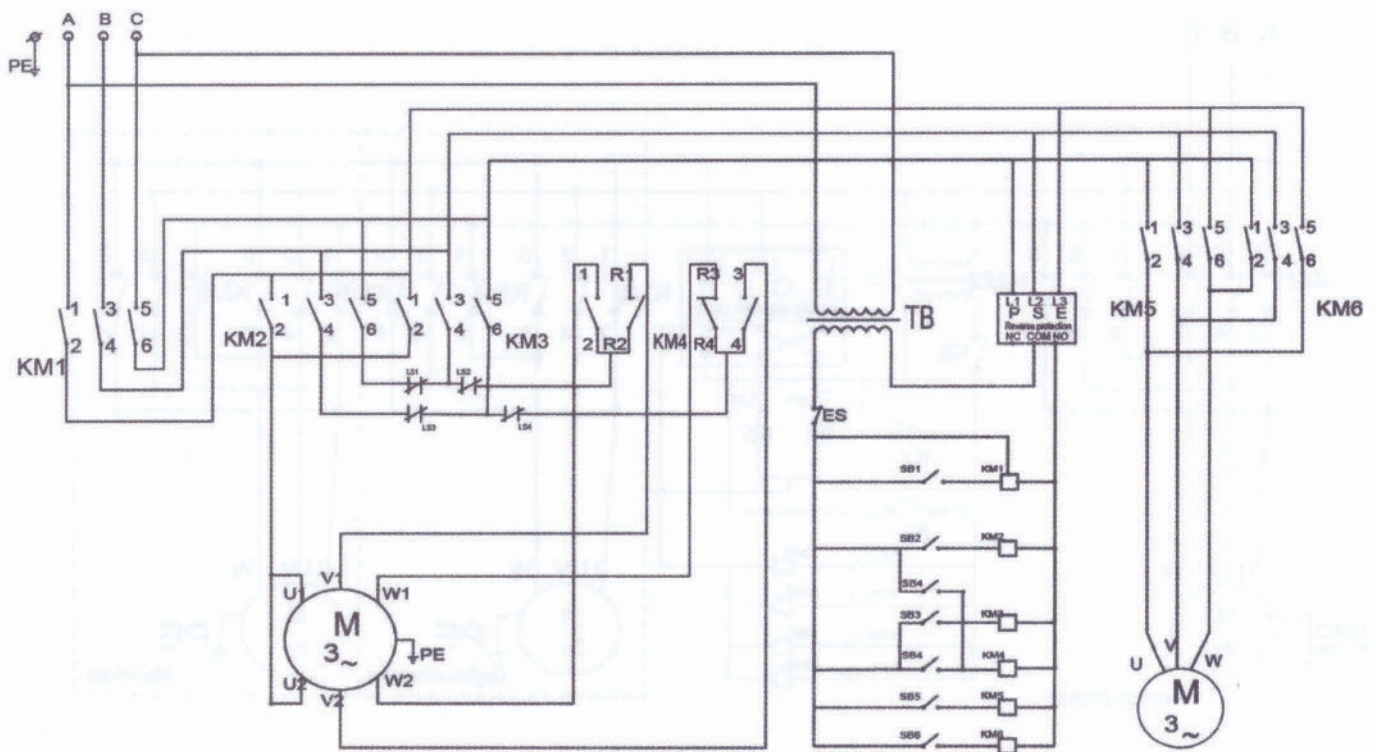

- |                                 |                        |
|---------------------------------|------------------------|
| ES emergency stop switch        | LS 1. LS 3 upper limit |
| SB1 mains contactor             | LS 2. LS 4 lower limit |
| SB2 slower control point        | TB control transformer |
| SB3 slow down the control point | PSE phasing            |
| SB4 rapid control point         | AC contactor KM1-KM6   |
| SB5 left control point          | PE Ground              |
| SB6 right control point         |                        |

## Single-speed automatic commutation control points 2-6 electrical schematics

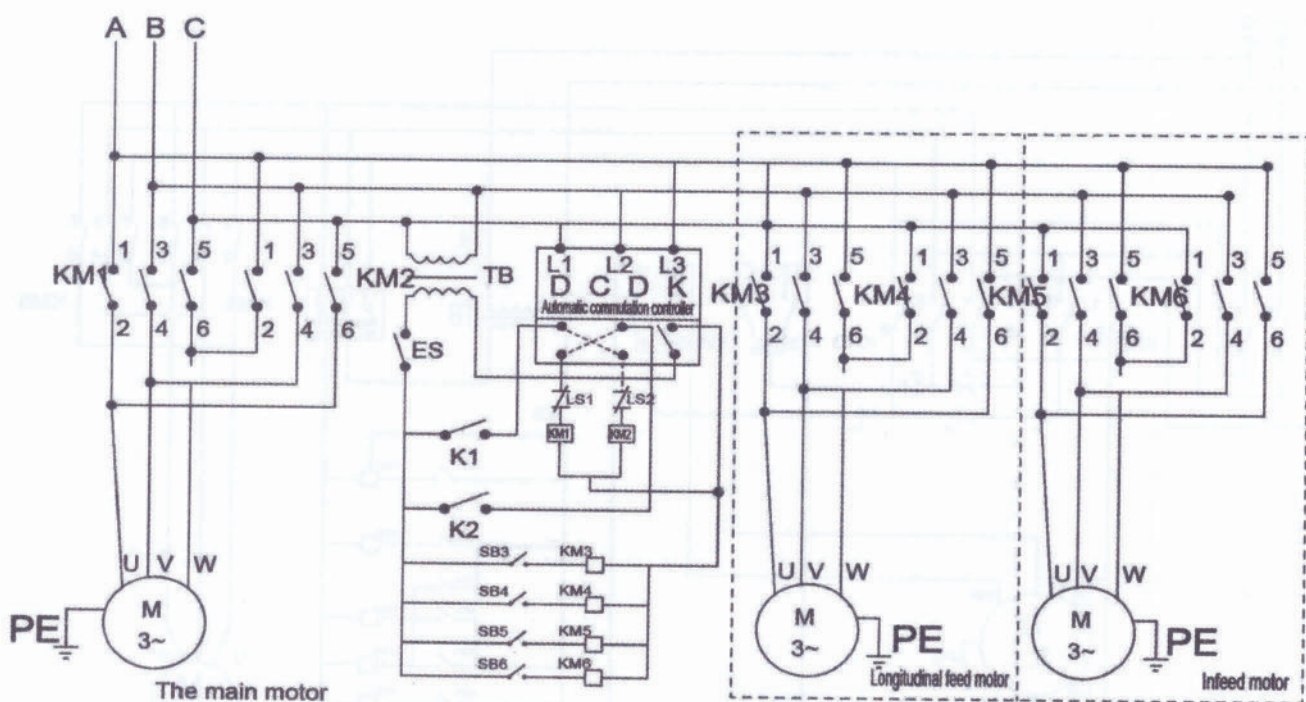

ES emergency stop switch  
 K1 on the control point  
 K2 under the control point  
 SB3 left control point  
 SB4 right control point  
 SB5 front handles  
 SB6 after the control point

LS 1 upper limit  
 LS 2 lower limit  
 TB control transformer  
 PASE automatic phase controller  
 AC contactor KM1-KM6  
 PE Ground

## 8. Drawing and parts list

VI-1 Motor and body assembly drawing	31
VI-1 Motor and body parts list	32
VI-2A Hook assembly drawing (0.5,1,1.5,2,2.5,3,5ton)	33
VI-2A Hook parts list(0.5,1,1.5,2,2.5,3,5ton)	34
VI-2B Hook assembly drawing(7.5ton)	35
VI-2B Hook assembly parts list(7.5ton)	36
VI-3 Gear box assembly drawing	37
VI-3 Gear box assembly parts list	38
VI-4 Chain assembly drawing	39
VI-4 Chain assembly parts list	40
VI-5 Gear box assembly drawing	41
VI-5 Gear box assembly parts list	42
VI-7 Electric trolley assembly drawing	43
VI-7 Electric trolley assembly parts list	44
VI-8 Handle trolley assembly drawing	45
VI-8 Handle trolley assembly parts list	45

VIII-1 Motor and body assembly drawing

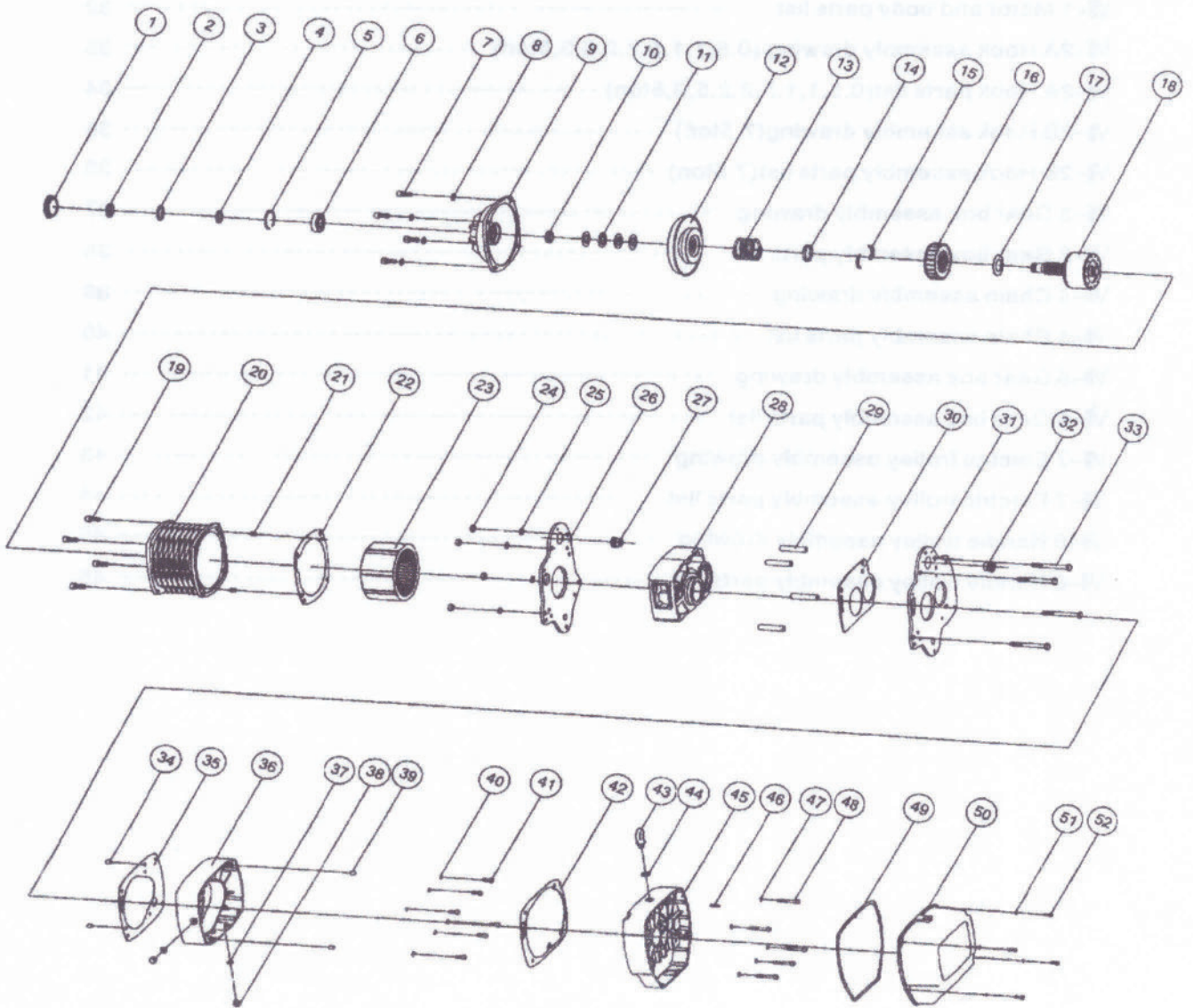

## VII-1 Motor and body parts list

S = SINGLE SPEED ; D = DUAL SPEEDS

Item	Spare Parts Name	Every Type Hoist Use Quantity															
		03-01,0.5-01		01-01		1.5-01		02-01		2.5-01		03-01		05-02		7.5-03	
		S	D	S	D	S	D	S	D	S	D	S	D	S	D	S	D
1	Rubber cover	1	1	1	1	1	1	1	1	1	1	1	1	1	1	1	1
2	Nut	1	1	1	1	1	1	1	1	1	1	1	1	1	1	1	1
3	Motor back end locking plate	1	1	1	1	1	1	1	1	1	1	1	1	1	1	1	1
4	Ring upper washer	1	1	1	1	1	1	1	1	1	1	1	1	1	1	1	1
5	Circlip for hole	1	1	1	1	1	1	1	1	1	1	1	1	1	1	1	1
6	Deep groove ball bearing	1	1	1	1	1	1	1	1	1	1	1	1	1	1	1	1
7	Socket head cap screw	4	4	4	4	4	4	4	4	4	4	4	4	4	4	4	4
8	Spring washer	4	4	4	4	4	4	4	4	4	4	4	4	4	4	4	4
9	Motor cover	1	1	1	1	1	1	1	1	1	1	1	1	1	1	1	1
10	Rotor washer	1	1	1	1	1	1	1	1	1	1	1	1	1	1	1	1
11	Plate spring	4	4	4	4	4	4	4	4	4	4	4	4	4	4	4	4
12	Brake pad assembly	1	1	1	1	1	1	1	1	1	1	1	1	1	1	1	1
13	Brake spring	1	1	1	1	1	1	1	1	1	1	1	1	1	1	1	1
14	Brake magnet locking sleeve	1	1	1	1	1	1	1	1	1	1	1	1	1	1	1	1
15	Brake magnet split ring	2	2	2	2	2	2	2	2	2	2	2	2	2	2	2	2
16	Brake magnet coil	1	1	1	1	1	1	1	1	1	1	1	1	1	1	1	1
17	Plate spring	1	1	1	1	1	1	1	1	1	1	1	1	1	1	1	1
18	Rotor assembly	1	1	1	1	1	1	1	1	1	1	1	1	1	1	1	1
19	Socket head cap screw	4	4	4	4	4	4	4	4	4	4	4	4	4	4	4	4
20	Motor shell	1	1	1	1	1	1	1	1	1	1	1	1	1	1	1	1
21	Spring-type straight pin	2	2	2	2	2	2	2	2	2	2	2	2	2	2	2	2
22	Gasket A	1	1	1	1	1	1	1	1	1	1	1	1	1	1	1	1
23	Motor stator	1	1	1	1	1	1	1	1	1	1	1	1	1	1	1	1
24	Hex nut	4	4	4	4	4	4	4	4	4	4	4	4	4	4	4	4
25	Spring washer	4	4	4	4	4	4	4	4	4	4	4	4	4	4	4	4
26	Motor bottom plate	1	1	1	1	1	1	1	1	1	1	1	1	1	1	1	1
27	Upper hook bearing bush	1	1	1	1	1	1	1	1	1	1	1	1	1	1	1	1
28	Chain wheel case	1	1	1	1	1	1	1	1	1	1	1	1	1	1	1	1
29	Sleeve	4	4	4	4	4	4	4	4	4	4	4	4	4	4	4	4
30	Gasket B	1	1	1	1	1	1	1	1	1	1	1	1	1	1	1	1
31	Bottom plate for gear box	1	1	1	1	1	1	1	1	1	1	1	1	1	1	1	1
32	Upper hook bearing bush	1	1	1	1	1	1	1	1	1	1	1	1	1	1	1	1
33	Sleeve bolt	4	4	4	4	4	4	4	4	4	4	4	4	4	4	4	4
34	Dowel pin	2	2	2	2	2	2	2	2	2	2	2	2	2	2	2	2
35	Gasket C	1	1	1	1	1	1	1	1	1	1	1	1	1	1	1	1
36	Middle ware	1	1	1	1	1	1	1	1	1	1	1	1	1	1	1	1
37	Hex screw washer	2	2	2	2	2	2	2	2	2	2	2	2	2	2	2	2
38	Hex screw	2	2	2	2	2	2	2	2	2	2	2	2	2	2	2	2
39	Dowel pin	2	2	2	2	2	2	2	2	2	2	2	2	2	2	2	2
40	Spring washer	6	6	6	6	6	6	6	6	6	6	6	6	6	6	6	6
41	Socket head cap bolt	6	6	6	6	6	6	6	6	6	6	6	6	6	6	6	6
42	Gasket D	1	1	1	1	1	1	1	1	1	1	1	1	1	1	1	1
43	Eye bolt	1	1	1	1	1	1	1	1	1	1	1	1	1	1	1	1
44	Eye bolt gasket	1	1	1	1	1	1	1	1	1	1	1	1	1	1	1	1
45	Gear box	1	1	1	1	1	1	1	1	1	1	1	1	1	1	1	1
46	Dowel pin	1	1	1	1	1	1	1	1	1	1	1	1	1	1	1	1
47	External toothed washer	5	5	5	5	5	5	5	5	5	5	5	5	5	5	5	5
48	Socket head cap bolt	5	5	5	5	5	5	5	5	5	5	5	5	5	5	5	5
49	Gasket E	1	1	1	1	1	1	1	1	1	1	1	1	1	1	1	1
50	Electrical section cover	1	1	1	1	1	1	1	1	1	1	1	1	1	1	1	1
51	Spring washer	4	4	4	4	4	4	4	4	4	4	4	4	4	4	4	4
52	Socket head cap bolt	4	4	4	4	4	4	4	4	4	4	4	4	4	4	4	4

**VI-2 A HOOK ASSEMBLY DRAWING**  
**(0.5,1,1.5,2,2.5,3,5TON)**

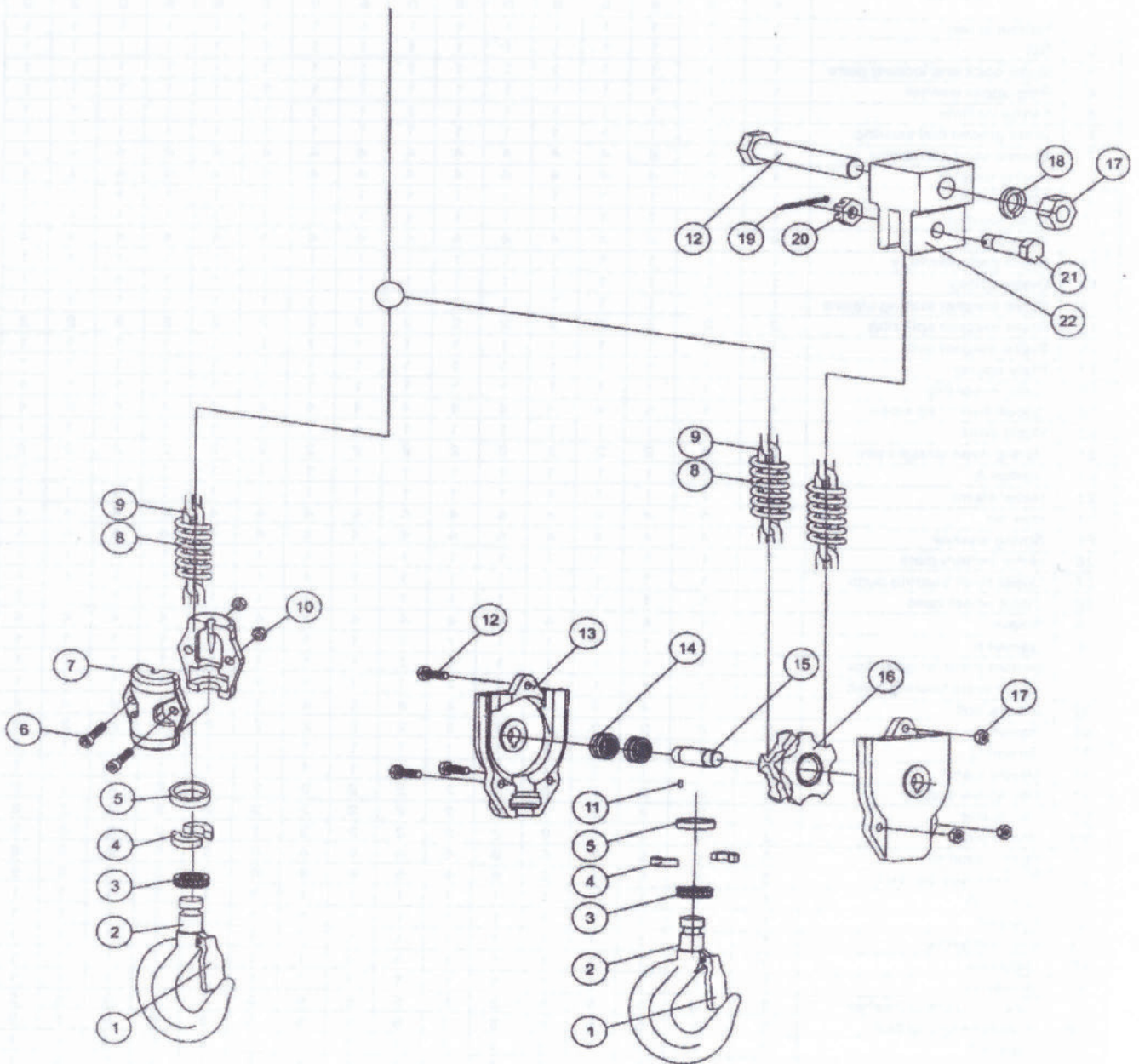

**VI-2A HOOK PARTS LIST(0.5,1,1.5,2,2.5,3,5TON)**

S = SINGLE SPEED ; D = DUAL SPEEDS

Item	Spare Parts Name	Every Type Hoist Use Quantity																	
		03-01,0.5-01		01-01		1.5-01		02-01		03-02		2.5-01		03-01		03-02		05-02	
		S	D	S	D	S	D	S	D	S	D	S	D	S	D	S	D	S	D
1	Hook safety latch	1	1	1	1	1	1	1	1	1	1	1	1	1	1	1	1	1	1
2	Lower hook	1	1	1	1	1	1	1	1	1	1	1	1	1	1	1	1	1	1
3	Thust ball bearing	1	1	1	1	1	1	1	1	1	1	1	1	1	1	1	1	1	1
4	Lower hook split ring	2	2	2	2	2	2	2	2	2	2	2	2	2	2	2	2	2	2
5	Lower hook locking sleeve	1	1	1	1	1	1	1	1	1	1	1	1	1	1	1	1	1	1
6	Socket head cap screw	2	2	2	2	2	2	2	2	/	/	2	2	2	2	/	/	/	/
7	Lower hook swivel shell	2	2	2	2	2	2	2	2	/	/	2	2	2	2	/	/	/	/
8	Chain limit spring	1	1	1	1	1	1	1	1	2	2	1	1	1	1	2	2	2	2
9	Chain	3m	3m	3m	3m	3m	3m	3m	3m	3m	3m	3m	3m	3m	3m	3m	3m	3m	3m
10	Self-locking nut	2	2	2	2	2	2	2	2	/	/	2	2	2	2	/	/	/	/
11	Slotted spring pins	/	/	/	/	/	/	/	/	1	1	/	/	/	/	1	1	1	1
12	Outer hexagonal shell	/	/	/	/	/	/	/	/	4	4	/	/	/	/	4	4	4	4
13	Lower load block shell	/	/	/	/	/	/	/	/	2	2	/	/	/	/	2	2	2	2
14	Needle bearing	/	/	/	/	/	/	/	/	2	2	/	/	/	/	2	2	2	2
15	Lower load block chain wheel shaft	/	/	/	/	/	/	/	/	1	1	/	/	/	/	1	1	1	1
16	Lower load chain wheel	/	/	/	/	/	/	/	/	1	1	/	/	/	/	1	1	1	1
17	Hexnut	/	/	/	/	/	/	/	/	4	4	/	/	/	/	4	4	4	4
18	Spring washer	/	/	/	/	/	/	/	/	1	1	/	/	/	/	1	1	1	1
19	Split pin	/	/	/	/	/	/	/	/	1	1	/	/	/	/	1	1	1	1
20	Hex slotted nut	/	/	/	/	/	/	/	/	1	1	/	/	/	/	1	1	1	1
21	Chain bolt	/	/	/	/	/	/	/	/	1	1	/	/	/	/	1	1	1	1
22	Chain locking block	/	/	/	/	/	/	/	/	1	1	/	/	/	/	1	1	1	1

# ELECTRIC CHAIN HOIST

## VIII-2B HOOK ASSEMBLY DRAWING(7.5TON)

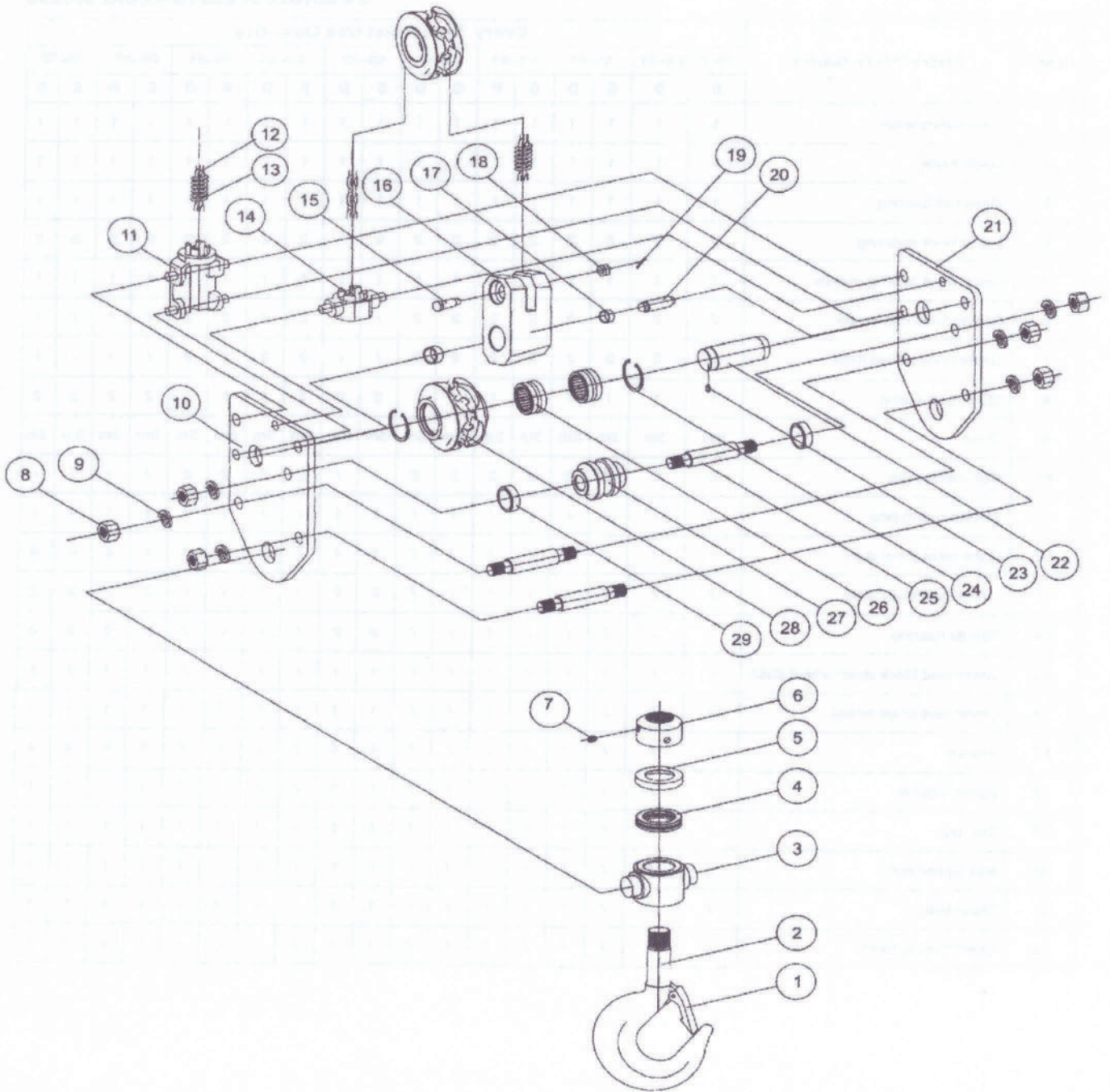

## VII-2B HOOK ASSEMBLY PARTS LIST(7.5TON)

S = SINGLE SPEED ; D = DUAL SPEEDS

Item	Spare Parts Name	Every Type Hoist Use Quantity	
		03-03,7.5-03	
		S	D
1	Hook safety latch	1	1
2	lower hook	1	1
3	Hook to undertake block	1	1
4	thrust ball bearing	1	1
5	Bearing sheath	1	1
6	Hook nut	1	1
7	Hex-end tight set screws	1	1
8	Hexnut	6	6
9	Spring washer	6	6
10	Stent motherboard under	1	1
11	Chain guiding for inlet and outlet	1	1
12	Chain	9m	9m
13	Limit spring	1	1
14	Guide chain body	1	1
15	Chain bolt	1	1
16	Chain locking block	1	1
17	Locking block of gasket	2	2
18	Hex slotted nut	1	1
19	Split pin	1	1
20	Locking block of shaft	1	1
21	Stent vice board under	1	1
22	lower hook chain wheel shaft	1	1
23	Spring straight pins	1	1
24	Circlip for hole	2	2
25	Stents double nut	3	3
26	Needle bearing	2	2
27	Guiding pulley	1	1
28	Chain wheel	1	1
29	Circlip	2	2

VII-3 Gear Box Assembly Drawing

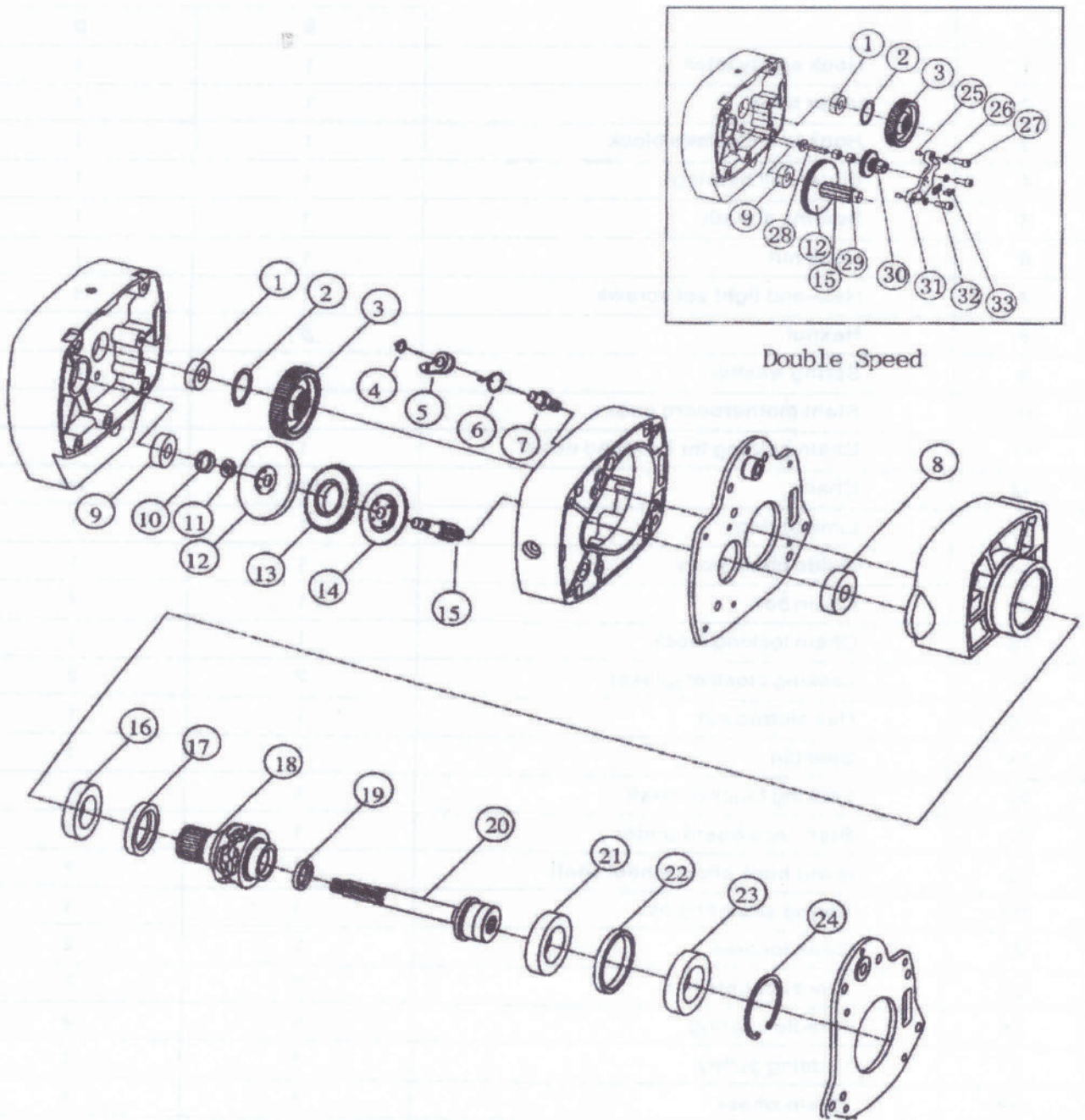

Double Speed

# ELECTRIC CHAIN HOIST

## VI-3 GEAR BOX ASSEMBLY PARTS LIST

S = SINGLE SPEED ; D = DUAL SPEEDS

Item	Spare Parts Name	Every Type Hoist Use Quantity													
		0.5-01		01-01		02-01		2.5-01		03-01		05-02		7.5-03	
		S	D	S	D	S	D	S	D	S	D	S	D	S	D
1	Deep groove ball bearing	1	1	1	1	1	1	1	1	1	1	1	1	1	1
2	Circlip for shaft	1	1	1	1	1	1	1	1	1	1	1	1	1	1
3	Output gear	1	1	1	1	1	1	1	1	1	1	1	1	1	1
4	Circlip for shaft	1	1	1	1	1	1	1	1	1	1	1	1	1	1
5	jumping gear	1	1	1	1	1	1	1	1	1	1	1	1	1	1
6	Torsion spring	1	1	1	1	1	1	1	1	1	1	1	1	1	1
7	breaking paul axle	1	1	1	1	1	1	1	1	1	1	1	1	1	1
8	Deep groove ball bearing	1	1	1	1	1	1	1	1	1	1	1	1	1	1
9	Deep groove ball bearing	1	1	1	1	1	1	1	1	1	1	1	1	1	1
10	fixed ring	1	1	1	1	1	1	1	1	1	1	1	1	1	1
11	Two and a half circle	1	1	1	1	1	1	1	1	1	1	1	1	1	1
12	gear	1	1	1	1	1	1	1	1	1	1	1	1	1	1
13	brake ratchet	1	1	1	1	1	1	1	1	1	1	1	1	1	1
14	brake disc	1	1	1	1	1	1	1	1	1	1	1	1	1	1
15	gear shaft	1	1	1	1	1	1	1	1	1	1	1	1	1	1
16	Deep groove ball bearing	1	1	1	1	1	1	1	1	1	1	1	1	1	1
17	oil seal	1	1	1	1	1	1	1	1	1	1	1	1	1	1
18	Chain wheel	1	1	1	1	1	1	1	1	1	1	1	1	1	1
19	oil seal	1	1	1	1	1	1	1	1	1	1	1	1	1	1
20	Output shaft assembly	1	1	1	1	1	1	1	1	1	1	1	1	1	1
21	Deep groove ball bearing	1	1	1	1	1	1	1	1	1	1	1	1	1	1
22	Bearings fixed ring	1	1	1	1	/	/	/	/	/	/	/	/	/	/
23	Deep groove ball bearing	1	1	1	1	1	1	1	1	1	1	1	1	1	1
24	Circlip for hole	1	1	1	1	1	1	1	1	1	1	1	1	1	1
25	Spring straight pins	/	2	/	2	/	2	/	2	/	2	/	2	/	2
26	Spring washer	/	3	/	3	/	3	/	3	/	3	/	3	/	3
27	Socket head cap screws	/	3	/	3	/	3	/	3	/	3	/	3	/	3
28	Reduction gear fixed axis	/	1	/	1	/	1	/	1	/	1	/	1	/	1
29	Bearing	/	2	/	2	/	2	/	2	/	2	/	2	/	2
30	Dual gears	/	1	/	1	/	1	/	1	/	1	/	1	/	1
31	Reduction gear fixed frame	/	1	/	1	/	1	/	1	/	1	/	1	/	1
32	Reduction gear fixed stator	/	1	/	1	/	1	/	1	/	1	/	1	/	1
33	Cross Becessed countersunk screw	/	2	/	2	/	2	/	2	/	2	/	2	/	2

# VI-4 CHAIN ASSEMBLY DRAWING

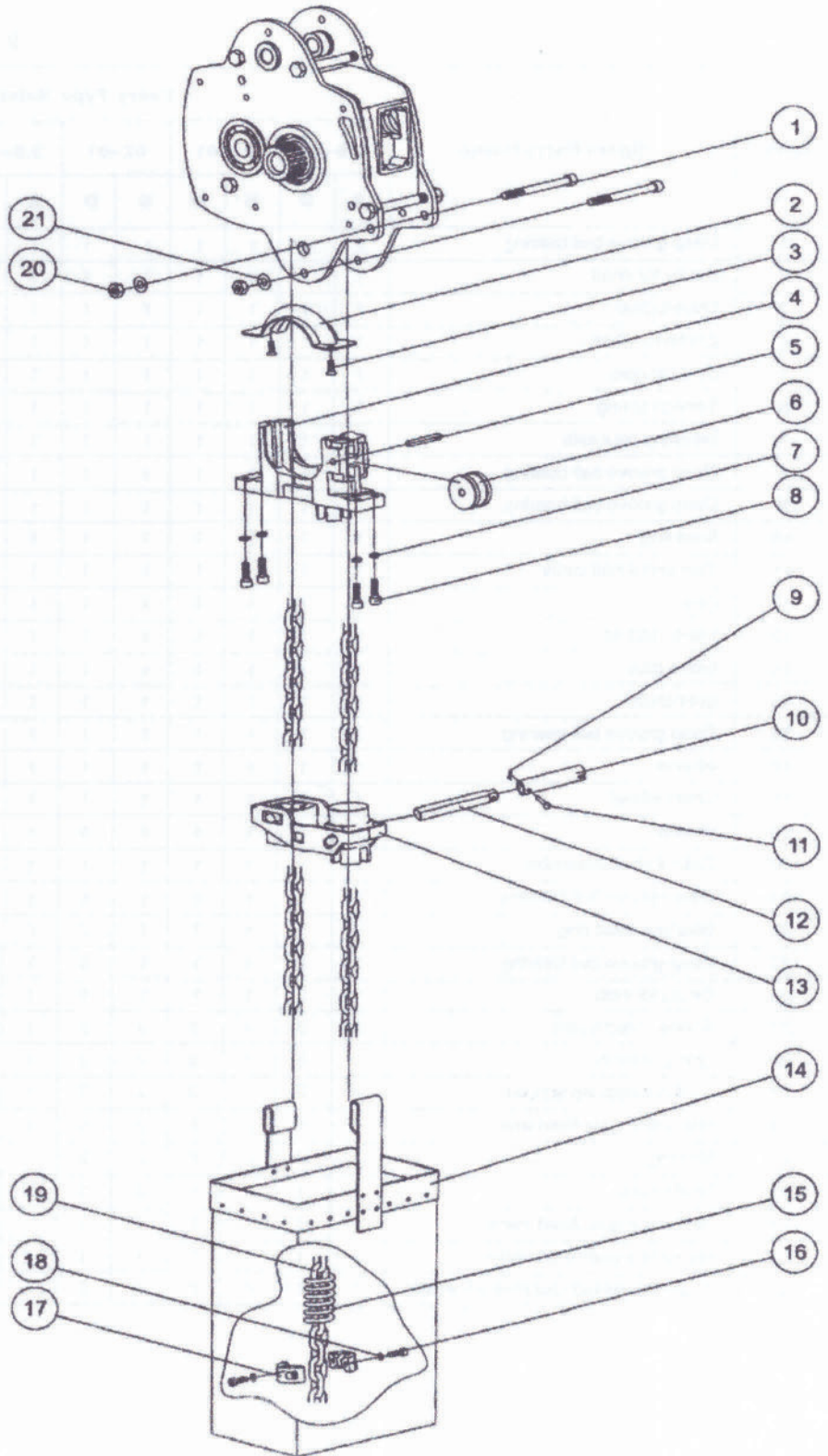

VI-4 CHAIN ASSEMBLY PARTS LIST

S = SINGLE SPEED ; D = DUAL SPEEDS

Item	Spare Parts Name	Every Type Hoist Use Quantity															
		03-01, 05-01		01-01		15-01		02-01		25-01		03-01		06-02		75-03	
		S	D	S	D	S	D	S	D	S	D	S	D	S	D	S	D
1	socket head cap screws	2	2	2	2	2	2	2	2	2	2	2	2	2	2	2	2
2	Oriented Iron	1	1	1	1	1	1	1	1	1	1	1	1	1	1	1	1
3	Slotted countersunk head screws	2	2	2	2	2	2	2	2	2	2	2	2	2	2	2	2
4	Chain Guide	1	1	1	1	1	1	1	1	1	1	1	1	1	1	1	1
5	Pulley Shaft	1	1	1	1	1	1	1	1	1	1	1	1	1	1	1	1
6	Oriented Pulley	1	1	1	1	1	1	1	1	1	1	1	1	1	1	1	1
7	Spring Washer	4	4	4	4	4	4	4	4	4	4	4	4	4	4	4	4
8	socket head cap screws	4	4	4	4	4	4	4	4	4	4	4	4	4	4	4	4
9	split pin	1	1	1	1	1	1	1	1	1	1	1	1	1	1	1	1
10	Limit switches connecting shaft	1	1	1	1	1	1	1	1	1	1	1	1	1	1	1	1
11	Axis of the Middle pin	1	1	1	1	1	1	1	1	1	1	1	1	1	1	1	1
12	Middle pin of guide frame	1	1	1	1	1	1	1	1	1	1	1	1	1	1	1	1
13	Guide frame assembly	1	1	1	1	1	1	1	1	1	1	1	1	1	1	1	1
14	Chain bag	1	1	1	1	1	1	1	1	1	1	1	1	1	1	1	1
15	Limit Spring	1	1	1	1	1	1	1	1	1	1	1	1	1	1	1	1
16	socket head cap screws	2	2	2	2	2	2	2	2	2	2	2	2	2	2	2	2
17	Chain split ring	2	2	2	2	2	2	2	2	2	2	2	2	2	2	2	2
18	Spring Washer	2	2	2	2	2	2	2	2	2	2	2	2	2	2	2	2
19	Chain	3m	3m	3m	3m	3m	3m	3m	3m	3m	3m	3m	3m	3m	3m	3m	3m
20	Nut	2	2	2	2	2	2	2	2	2	2	2	2	2	2	2	2
21	Spring Washer	2	2	2	2	2	2	2	2	2	2	2	2	2	2	2	2

### VI-5 Gear box assembly drawing

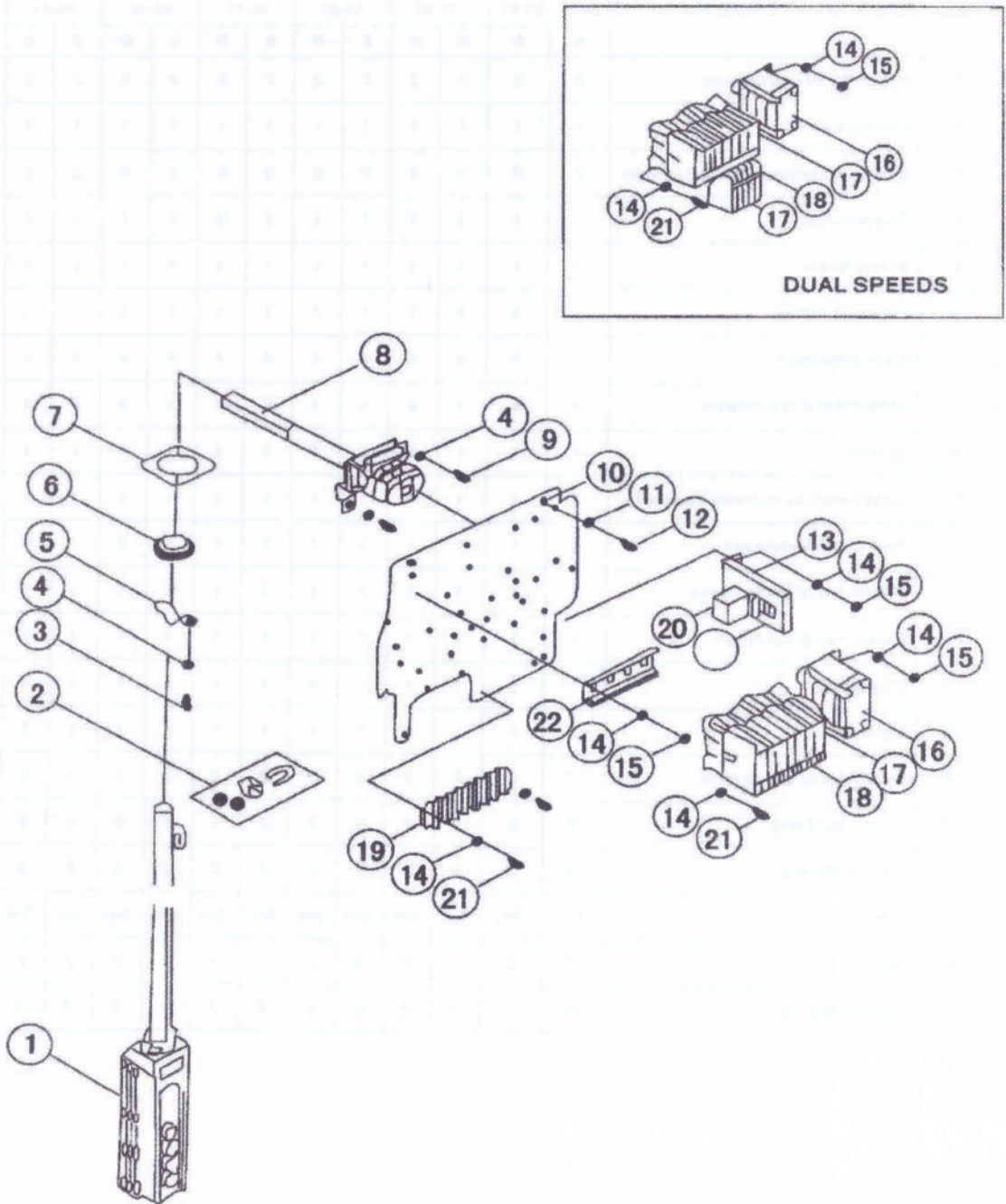

# ELECTRIC CHAIN HOIST

## VI-5 GEAR BOX ASSEMBLY PARTS LIST

S = SINGLE SPEED ; D = DUAL SPEEDS

Item	Spare Parts Name	Every Type Hoist Use Quantity															
		03-01, 0.5-01		01-01		1.5-01		02-01		2.5-01		03-01		05-02		7.5-03	
		S	D	S	D	S	D	S	D	S	D	S	D	S	D	S	D
1	Control switch	1	1	1	1	1	1	1	1	1	1	1	1	1	1	1	1
2	Tightrope Buckle	1	1	1	1	1	1	1	1	1	1	1	1	1	1	1	1
3	Round cross screw M6*12	2	2	2	2	2	2	2	2	2	2	2	2	2	2	2	2
4	Spring Washer	4	4	4	4	4	4	4	4	4	4	4	4	4	4	4	4
5	Wiring fixed ring accessories	1	1	1	1	1	1	1	1	1	1	1	1	1	1	1	1
6	Cable sheath	1	1	1	1	1	1	1	1	1	1	1	1	1	1	1	1
7	Fixed wiring ring	1	1	1	1	1	1	1	1	1	1	1	1	1	1	1	1
8	Connecting shaft assembly for control switch	1	1	1	1	1	1	1	1	1	1	1	1	1	1	1	1
9	Round cross screw M6*10	2	2	2	2	2	2	2	2	2	2	2	2	2	2	2	2
10	Electrical installation plate	1	1	1	1	1	1	1	1	1	1	1	1	1	1	1	1
11	Spring Washer ?6	4	4	4	4	4	4	4	4	4	4	4	4	4	4	4	4
12	Round cross screw M6*15	4	4	4	4	4	4	4	4	4	4	4	4	4	4	4	4
13	Reverse bracket B	1	1	1	1	1	1	1	1	1	1	1	1	1	1	1	1
14	Spring Washer φ4	5	5	5	5	5	5	5	5	5	5	5	5	5	5	5	5
15	Round cross screw M4*10	5	5	5	5	5	5	5	5	5	5	5	5	5	5	5	5
16	Transformer	1	1	1	1	1	1	1	1	1	1	1	1	1	1	1	1
17	Electromagnetic contactor	2	2	2	2	2	2	2	2	2	2	2	2	2	2	2	2
18	Mechanical linkage	1	1	1	1	1	1	1	1	1	1	1	1	1	1	1	1
19	Terminal block	1	1	1	1	1	1	1	1	1	1	1	1	1	1	1	1
20	Antiphase protector	1	1	1	1	1	1	1	1	1	1	1	1	1	1	1	1
21	Round cross screw M4*15	2	2	2	2	2	2	2	2	2	2	2	2	2	2	2	2
22	Fixed rail	1	1	1	1	1	1	1	1	1	1	1	1	1	1	1	1

# VI-7 ELECTRIC TROLLEY ASSEMBLY DRAWING

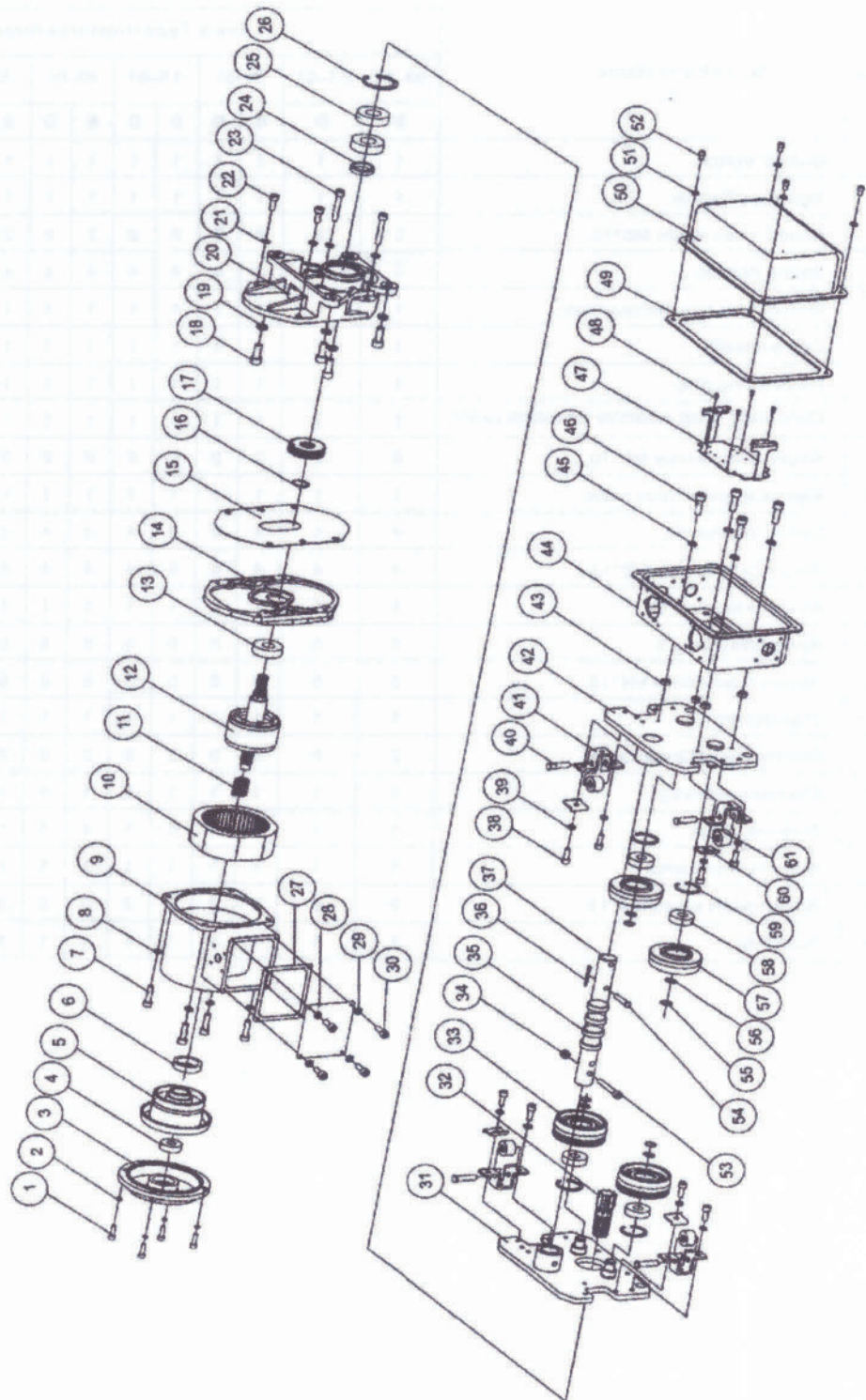

# ELECTRIC CHAIN HOIST

## VI-7 ELECTRIC TROLLEY ASSEMBLY PARTS LIST

S = SINGLE SPEED ; D = DUAL SPEEDS

Item	Spare Parts Name	Every Type Hoist Use Quantity						Item	Spare Parts Name	Every Type Hoist Use Quantity					
		0.5t	01t	02t	03t	05t	7.5t			0.5t	01t	02t	03t	05t	7.5t
1	socket head cap screwsM6*20	4	4	4	4	4	4	32	spline gear shaft	1	1	1	1	1	1
2	spring washer $\phi 6$	4	4	4	4	4	4	33	toothed driving wheel	2	2	2	2	2	2
3	motor back end cover	1	1	1	1	1	1	34	self-locking nut	1	1	1	1	1	1
4	deep groove ball bearing6202	1	1	1	1	1	1	35	adjusting spacer	8	8	8	8	8	8
5	5-Brake Assembly	1	1	1	1	1	1	36	split pin	1	1	1	1	1	1
6	rubber circlip	1	1	1	1	1	1	37	trolley shaft	1	1	1	1	1	1
7	socket head cap screws	4	4	4	4	4	4	38	socket head cap screw	8	8	8	8	8	8
8	spring washer	4	4	4	4	4	4	39	spring washer	8	8	8	8	8	8
9	motor shell	1	1	1	1	1	1	40	auxiliary wheel shaft	4	4	4	4	4	4
10	motor stator	1	1	1	1	1	1	41	auxiliary wheel bracket	4	4	4	4	4	4
11	brake spring	1	1	1	1	1	1	42	trolley subplate assembly	1	1	1	1	1	1
12	rotor assembly	1	1	1	1	1	1	43	gasket	4	4	4	4	4	4
13	deep groove ball bearing	1	1	1	1	1	1	44	electric control case shell assembly	1	1	1	1	1	1
14	motor bottom plate	1	1	1	1	1	1	45	spring washer	4	4	4	4	4	4
15	motor bottom plate gasket	1	1	1	1	1	1	46	socket head cap screw	4	4	4	4	4	4
16	circlip for shaft	1	1	1	1	1	1	47	wire connection bracket	1	1	1	1	1	1
17	gear	1	1	1	1	1	1	48	Cross Recess Head Screw	4	4	4	4	4	4
18	socket head cap screw	4	4	4	4	4	4	49	electric control case shell gasket	1	1	1	1	1	1
19	spring washer	4	4	4	4	4	4	50	electric control case shell	1	1	1	1	1	1
20	gear box	1	1	1	1	1	1	51	spring washer	4	4	4	4	4	4
21	spring washer	4	4	4	4	4	4	52	socket head cap screw	4	4	4	4	4	4
22	socket head cap screws	2	2	2	2	2	2	53	socket head cap screw	1	1	1	1	1	1
23	socket head cap screws	2	2	2	2	2	2	54	trolley shaft dowel pin	1	1	1	1	1	1
24	circlip	1	1	1	1	1	1	55	circlip for shaft	4	4	4	4	4	4
25	deep groove ball bearing	2	2	2	2	2	2	56	trolley wheel washer	4	4	4	4	4	4
26	circlip for hole	1	1	1	1	1	1	57	trolley wheel	2	2	2	2	2	2
27	side plate gasket	1	1	1	1	1	1	58	Deep groove ball rolling bearing	4	4	4	4	4	4
28	side plate	1	1	1	1	1	1	59	circlip for hole	4	4	4	4	4	4
29	spring washer	4	4	4	4	4	4	60	auxiliary wheel bracket gasket	4	4	4	4	4	4
30	socket head cap screw	4	4	4	4	4	4	61	trolley auxiliary wheel	4	4	4	4	4	4
31	trolley main plate assembly	1	1	1	1	1	1								

## VI-8 TROLLEY ASSEMBLY DRAWING

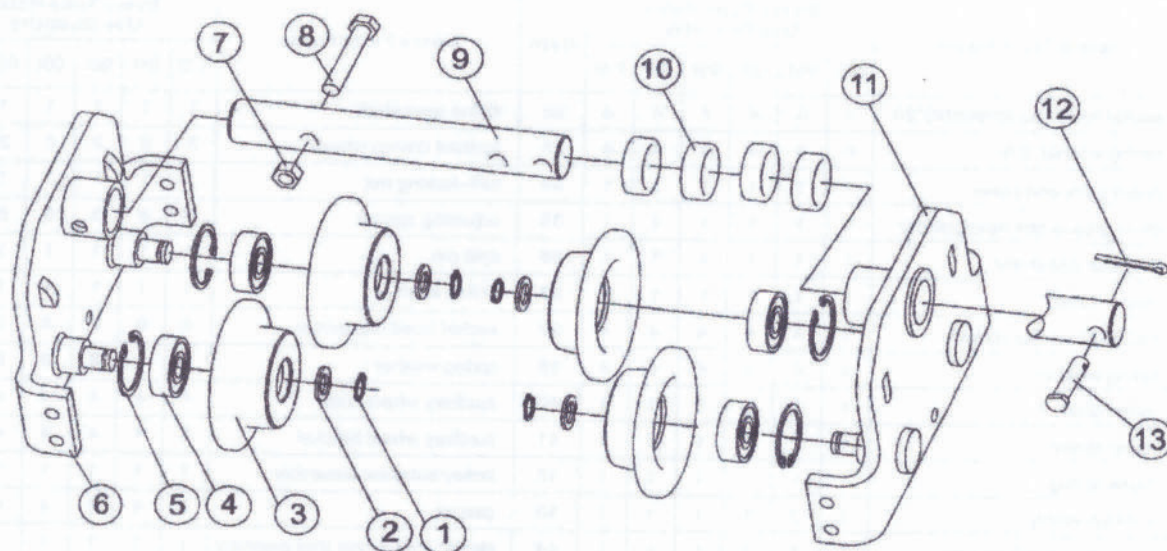

## VI-8 TROLLEY ASSEMBLY PARTS LIST

Item	Spare Parts Name	Every Type Hoist Use Quantity				
		0.5t	01t	02t	03t	05t
1	Circlip for shaft	4	4	4	4	4
2	Trolley wheel washer	4	4	4	4	4
3	Trolley wheel	4	4	4	4	4
4	Deep groove ball bearing	4	4	4	4	4
5	Circlip for hole	4	4	4	4	4
6	Trolley main plate assembly	1	1	1	1	1
7	Self-locking nut	1	1	1	1	1
8	Outer hexagonal screw	1	1	1	1	1
9	Trolley shaft	1	1	1	1	1
10	Adjusting spacer	8	8	8	8	8
11	Trolley subplate assembly	1	1	1	1	1
12	Split pin	1	1	1	1	1
13	Trolley shaft dowel pin	1	1	1	1	1

## 9 Common problems and processing

Conditions	Reasons	How to solve
The hoist can not be operated	<ol style="list-style-type: none"> <li>(1) The power phases are linked wrongly, which results in the start of the phase protection and makes it unable to operate.</li> <li>(2) The power fuse is burned or the no-fuse switch is off.</li> <li>(3) The fuse in the control circuit burns.</li> <li>(4) The power cord or the wire of the control circuit breaks or is not linked properly.</li> <li>(5) The voltage is too low.</li> <li>(6) The motor makes a sound but does not rotate.</li> <li>(7) The emergency switch is pressed (if installed).</li> <li>(8) The contactor is bad.</li> </ol>	<ol style="list-style-type: none"> <li>(1) Exchange the power cords of the two phases.</li> <li>(2) Check whether the current is normal, replace a proper fuse or restart the non-fuse switch.</li> <li>(3) Check whether the current is normal, and replace a proper fuse.</li> <li>(4) Repair or replace the electricity wire that breaks or has bad contact.</li> <li>(5) Measure whether the voltage is over 10% lower than the standard voltage.</li> <li>(6) Check whether the motor phase is correct-repair and make proper insulation.</li> <li>(7) Confirm the reason of pressing the emergency switch.</li> <li>(8) a. Operate the hoist manually, if it works properly, it means that the control coil or cable has bad contact-find out the location of bad contact and have it repaired. b. If the hoist can not be operated manually, it is necessary to check whether the main power supply is normal. If the main power supply is ok, it is caused by bad contact. If it is unable to output normally, the contactor should be replaced.</li> </ol>
The hoist can not be stopped	The coil of the contactor fuses (it is in short circuit fault).	Replace the contactor.
The brake slides	The motor brake wears.	Replace the friction disc.
The chain/chain wheel of the lower hook makes abnormal noise	<ol style="list-style-type: none"> <li>(1) The chain is not lubricated enough and properly.</li> <li>(2) The chain wheel is worn.</li> </ol>	<ol style="list-style-type: none"> <li>(1) Lubrication.</li> <li>(2) Replace the chain and chain wheel.</li> </ol>
Electric leakage	<ol style="list-style-type: none"> <li>(1) Imperfect earth.</li> <li>(2) The dusts in air gather on electrical parts or the humidity is too high.</li> </ol>	<ol style="list-style-type: none"> <li>(1) Provide perfect earth.</li> <li>(2) Keep the electrical parts clean and make humidity low.</li> </ol>
Oil leakage	<ol style="list-style-type: none"> <li>(1) The oil plug is not applied.</li> <li>(2) The oil plug is loose.</li> <li>(3) The oil plug gasket is not installed.</li> <li>(4) The gasket is worn or deteriorated.</li> </ol>	<ol style="list-style-type: none"> <li>(1) Install a proper plug.</li> <li>(2) Tighten the plug.</li> <li>(3) Install a proper plug gasket or replace a new gasket.</li> </ol>

## 10 Instructions of using and inspecting for electric chain hoist

**Caution: When using the electric chain hoist, conduct in accordance with the following items:**

1. Confirm that the ISO level of electric chain hoist in use is in accordance with using conditions.
2. No overloading.
3. Electric chain hoist must be equipped with appointed chain.
4. It is forbidden to use if the lifting height of electric chain hoist is short.
5. Daily check-up before use.
6. Before use, check chains and links whether they are loose, twisted or twined. Make maintenance before use.
7. It is forbidden to use if the anti-separation device of lower hook is valid or lack.
8. It is forbidden to use if the chain is lack of up and down stop device.
9. It is forbidden to use if the chain is twined with the weights.
10. It is forbidden to use the front end of hook to lift the weights.
11. Do not make repeated operation about lifting up and down rapidly.
12. Do not lift beyond the up and down limit switch.
13. Do not walk or stand under the hoist when lifting.
14. Do not lift the weights slanting (within 15 degrees)
15. Prevent the electric chain hoist falling down.
16. If the operation frequency is high, the chain of electric chain hoist should be replaced annually.
17. Under the following special conditions, such as below  $-40^{\circ}\text{C}$ , above  $100^{\circ}\text{C}$ , corrosive or explosive environment, the chain should be replaced every six months, and the lower hook should be replaced every two years. (If the operation frequency is high, the lower hook should be examined annually and replaced every two years.)
18. If in the electroplate, heat treatment plant, the surface of hoist should be do periodic inspection monthly, and chain should be replaced annually.
19. After breaking, the chain can not be welded by yourself.
20. Chain should be lubricated before operation.
21. Gears, bearings and other friction parts should be added lubricants timely.
22. When not using hoist in a long time, please safely keep after doing proper rust proofing.
23. Electric chain hoist users will not be permitted to modify, if necessary, commission factory to modify.
24. It should be avoided to lift the weights with two hoists at the same time, it is dangerous. If in extreme circumstance, it should lift carefully within the range of sufficient loading capacity.